

TM 11-6625-842-24P

---

**TECHNICAL MANUAL**

**ORGANIZATIONAL, DIRECT SUPPORT, AND GENERAL SUPPORT MAINTENANCE  
REPAIR PARTS AND SPECIAL TOOLS LISTS  
(INCLUDING DEPOT MAINTENANCE REPAIR PARTS AND SPECIAL TOOLS)**

**FOR**

**TEST SET, TRANSPONDER SET  
AN/APM-239A  
(NSN 6625-00-802-7425)**

---

**HEADQUARTERS, DEPARTMENT OF THE ARMY  
MAY 1977**



TECHNICAL MANUAL  
 NO. 11-6625-842-24P

**HEADQUARTERS  
 DEPARTMENT OF THE ARMY**  
 WASHINGTON, DC, 5 May 1977

ORGANIZATIONAL, DIRECT SUPPORT, AND GENERAL SUPPORT MAINTENANCE  
 REPAIR PARTS AND SPECIAL TOOLS LISTS  
 (INCLUDING DEPOT MAINTENANCE REPAIR PARTS AND SPECIAL TOOLS)  
 FOR  
 TEST SET, TRANSPONDER SET AN/APM-239A  
 (NSN 6625-00-802-7425)

Current as of 15 December 1976

**REPORTING OF ERRORS**

**You can improve" this manual by recommending improvements using DA Form 2028-2 (Test) located in the back of the manual. Simply tear out the self-addressed form, fill it out as shown on the sample, fold it where shown, and drop it in the mail.**

**If there are no blank DA Forms 2028-2 (Test) in the back of your manual, use the standard DA Form 2028 (Recommended Changes to Publications and Blank Forms) and forward to the Commander, US Army Electronics Command, ATTN: DRSELMA-Q, Fort Monmouth, New Jersey 07703.**

**In either case a reply will be furnished direct to you.**

**Table of Contents**

	<u>Page</u>	<u>Illus. Figure</u>
SECTION I Introduction . . . . .	1	
H Repair parts list . . . . .	5	
Group 00 Test Set, Transponder Set AN/APM-239A	9	1.2
01 Test Set, Transponder Set TS-2681/APM-239A 119066-1 . . . . .	13	3
0101 Panel assembly, test set 119067-1 . . . . .	17	4
010101 Circuit card assembly 119064-1 . . . . .	18	5
0102 Case, Test Set CY-6477/APM-239A . . . . .	18	6
0103 Control, Transponder Set C-6280(P)/APX or C-6280A(P)/APX (See TM 11-5841-268-25P for parts)	19	
02 Cable Assembly, Special Purpose, Electrical CX -10905/APM-239A	20	6
03 Cable Assembly, Power, Electrical CX - 10926/APM-239A . . . . .	21	9
04 Cable Assembly, Special Purpose, Electrical CX -10908/APM-239A	22	10
05 Cable Assembly, Special Purpose, Electrical CX -10909/APM-239A. . . . .	23	11
06 Cable Assembly, Special Purpose, Electrical CX- 10907/APM-239A	24	12
07 Cable Assembly, Special Purpose, Electrical CX -10910/APM-239A	25	13
08 Cable Assembly, Radio Frequency CG-3470/APM-239A	26	14
09 Cable Assembly, Special Purpose, Electrical CX -11734/APM-239A	27	15
10 Cable Assembly, Special Purpose, Electrical CX -11735/APM-239A. . . . .	27	
SECTION III. Special tools list (Not applicable)		
Iv. National stock number and part number index. . . . .	28	

\*This manual supersedes TM 11-6625-843-25P. 2 April 1969.



## SECTION I INTRODUCTION

### 1. Scope.

This manual lists spares and repair parts; special tools; special test, measurement, and diagnostic equipment (TMDE), and other special support equipment required for performance of organizational, direct support, and general support maintenance of the AN/APM-239A. It authorizes the requisitioning and issue of spares and repair parts as indicated by the source and maintenance codes,

### 2. General

This Repair Parts and Special Tools List is divided into the following sections:

- a. Section II. Repair Parts List. A list of spares and repair parts authorized for use in the performance of maintenance. The list also includes parts which must be removed for replacement of the authorized parts. Parts lists are composed of functional groups in numeric sequence, with the parts in each group listed in figure and item number sequence.
- b. Section III. Special Tools List, Not applicable.
- c. Section IV. National Stock Number and Part Number Index. A list, in National item identification number (NUN) sequence, of all National stock numbers (NSN) appearing in the listings, followed by a list, in alphameric sequence, of all part numbers appearing in the listings. National stock numbers and part numbers are cross-referenced to each illustration figure and item number appearance.

### 3. Explanation of Columns

- a. Illustration. This column is divided as follows:
  - (1) Figure number. Indicates the figure number of the illustration on which the item is shown.
  - (2) Item number. The number used to identify item called out in the illustration.
- b. *Source, Maintenance, and Recoverability (SMR) Codes.*
  - (1) *Source code.* Source codes indicate the manner of acquiring support items for maintenance, repair or overhaul of end items. Source codes are entered in the first and second positions of the Uniform SMR Code format as follows:
 

<i>Code</i>	<i>Definition</i>
PA-	Item procured and stocked for anticipated or known usage.
PD-	Support item, excluding support equipment pro-

#### *Code*

#### *Definition*

- cured* for initial issue or outfitting and stocked only for subsequent or additional initial issues or outfittings. Not subject to automatic replenishment.
- XD-A support item that is not stocked. When required, item will be procured through normal supply channels.

#### NOTE

- Cannibalization or salvage may be used as a source of supply for any items source coded above except those coded XA and aircraft support items as restricted by AR 700-42.
- (2) *Maintenance code.* Maintenance codes are assigned to indicate the levels of maintenance authorized to USE and REPAIR support items. The maintenance codes are entered in the third and fourth positions of the Uniform SMR Code format as follows:

- (a) The maintenance code entered in the third position will indicate the lowest maintenance level authorized to remove, replace, and use the support item. The maintenance code entered in the third position will indicate one of the following levels of maintenance:

- |             |   |
|-------------|---|
| <i>Code</i> | <i>Application/Explanation</i>  |
| O-          | Support item is removed, replaced, used at the organizational level.  |
| H-          | Support item is removed, replaced, used at the general support level. |

- (b) The maintenance code entered in the fourth position indicates whether the item is to be repaired and identifies the lowest maintenance level with the capability to perform complete repair (i.e., all authorized maintenance functions). This position will contain one of the following maintenance codes:

- |             |   |
|-------------|---|
| <i>Code</i> | <i>Application/Explanation</i>  |
| H-          | The lowest maintenance level capable of complete repair of the support item is the general support level. |
| Z-          | Nonreparable. No repair is authorized   |

- (3) *Recoverability code.* Recoverability codes are assigned to support items to indicate the disposition action on unserviceable items. The recoverability code is entered in the fifth position of the Uniform SMR Code format as follows.





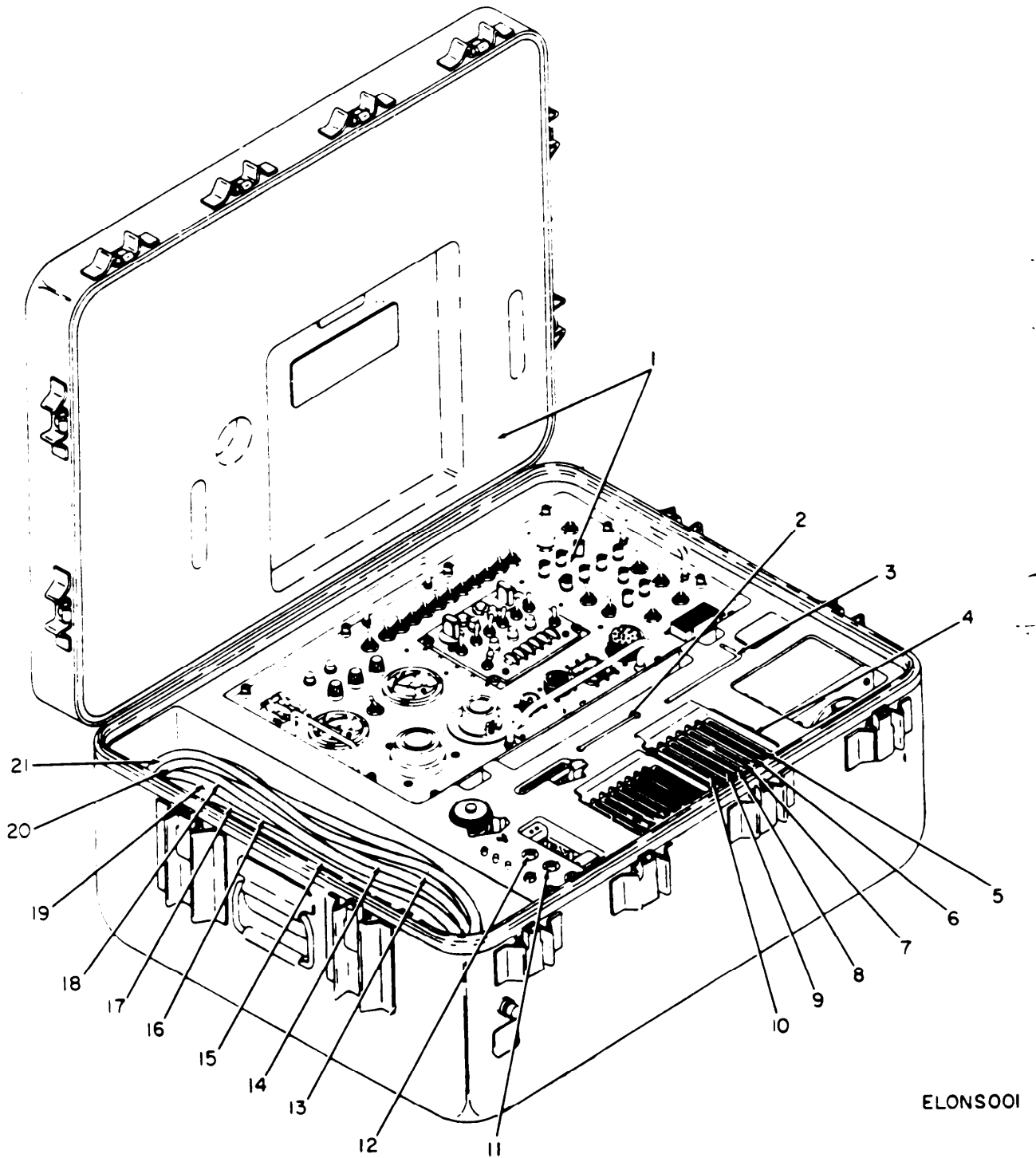
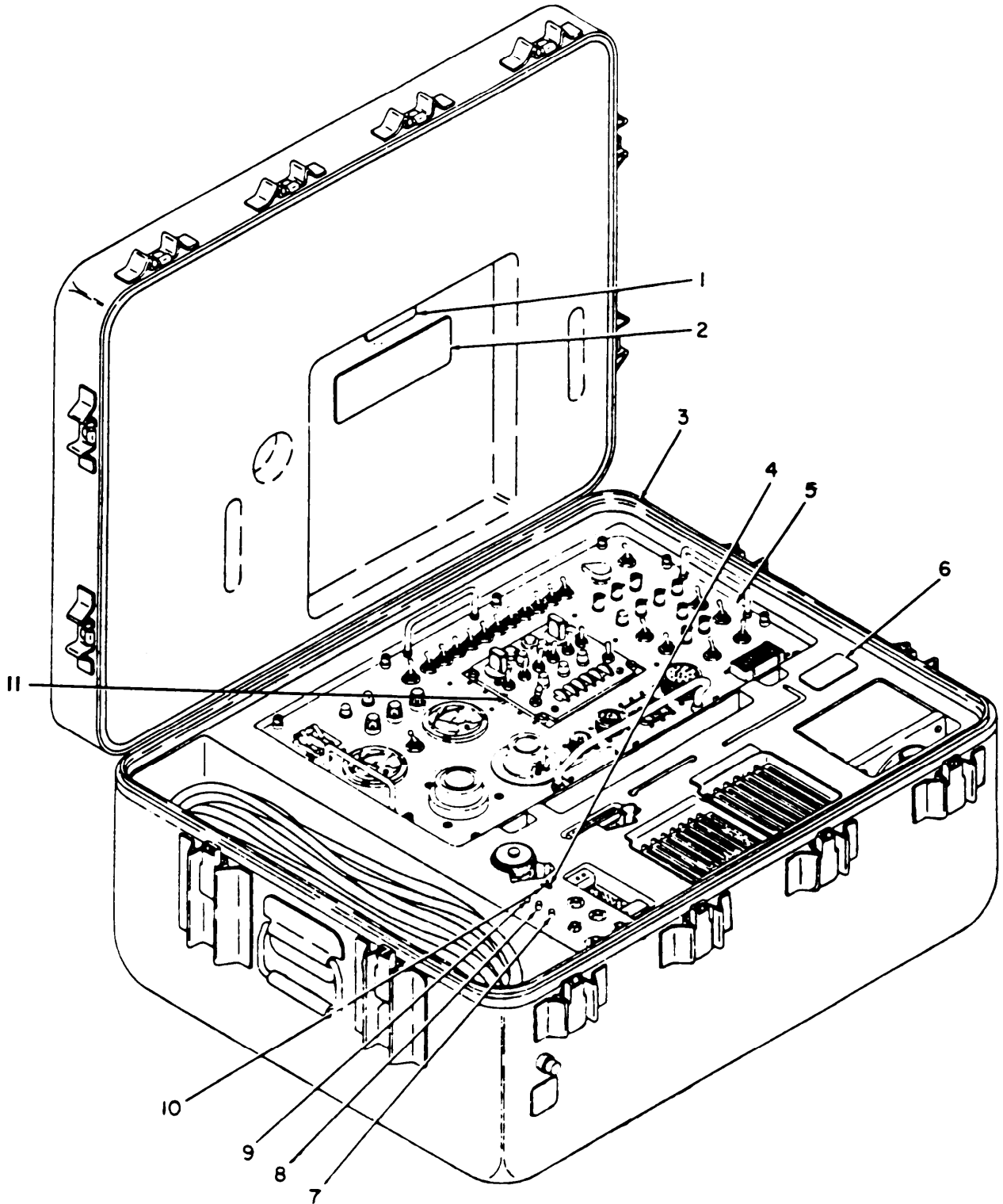

Figure 1. Test Set, Transponder Set AN/APM-239A.



SECTION II						TM11-6625-842-24P		
(1)	(2)	(3)	(4)	(5)	(6)	(7)	(8)	
ILLUSTRATION					DESCRIPTION		QTY	
(A)	(B)	NATIONAL	PART	FSCM		USABLE ON CODE	INC	
FIG	ITEM	STOCK	NUMBER				IN	
NO	NO	NUMBER	NUMBER				UNIT	
					GROUP 00 TEST SET, TRANSPONDER SET AN/APM-239A			
1	1	PAOHH 6625-00-802-7425	119598-1	80249	TEST SET, TRANSPONDER AN/APM-239A	EA	1	
1	2	PAOZZ 5120-00-996-4508	880007	80249	FULLER, PRINTED CIRCUIT BOARD	EA	1	
1	3	PAOZZ 5120-00-020-0176	880177	80249	REMOVAL TOOL, CONNECTOR	EA	1	
1	4	XDHZZ 119155-1	119155-1	80249	RACK, PRINTED CIRCUIT BOARD	EA	1	
1	5	PAOZZ 6625-00-107-7982	119165-2	80249	ADAPTER, TEST MX-8203/APM-239A	EA	1	
1	6	PAOZZ 6625-00-107-8013	119198-2	80249	ADAPTER, TEST MX-8207/APM-239A	EA	1	
1	7	PAOZZ 6625-00-107-7968	119165-1	80249	ADAPTER, TEST MX-8202/APM-239A	EA	1	
1	8	PAOZZ 6625-00-107-8126	119198-1	80249	ADAPTER, TEST MX-8206/APM-239A	EA	1	
1	9	PAOZZ 6625-00-107-8009	119165-4	80249	ADAPTER, TEST MX-8205/APM-239A	EA	1	
1	10	PAOZZ 6625-00-107-7987	119165-3	80249	ADAPTER, TEST MX-8204/APM-239A	EA	1	
1	11	PAOZZ 5935-00-557-9862	UG636AU	81349	ADAPTER, CONNECTOR	EA	1	
1	12	PAOZZ 5935-00-259-0205	UG201U	81349	ADAPTER, CONNECTOR	EA	1	
1	13	PAOHH 6625-00-109-6133	119073-1	80249	CABLE ASSEMBLY, SPECIAL PURPOSE, ELECTRICAL CX-10905/APM-239A	EA	1	
1	14	XDOHH 119058-1	119058-1	80249	CABLE ASSEMBLY, POWER, ELECTRICAL CX-10926/APM-239A	EA	1	
1	15	PAOHH 6625-00-195-1579	119076-1	80249	CABLE ASSEMBLY, SPECIAL PURPOSE, ELECTRICAL CX-10908/APM-239A	EA	1	
1	16	XDOHH 119077-1	119077-1	80249	CABLE ASSEMBLY, SPECIAL PURPOSE, ELECTRICAL CX-10909/APM-239A	EA	1	
1	17	XDOHH 119078-1	119078-1	80249	CABLE ASSEMBLY, SPECIAL PURPOSE, ELECTRICAL CX-10907/APM-239A	EA	1	
1	18	XDOHH 119079-1	119079-1	80249	CABLE ASSEMBLY, SPECIAL PURPOSE, ELECTRICAL CX-10910/APM-239A	EA	1	
1	19	XDOHH 119162-1	119162-1	80249	CABLE ASSEMBLY, RADIO FREQUENCY CG-3470/APM-239A	EA	1	
1	20	XDOHH 119163-1	119163-1	80249	CABLE ASSEMBLY, SPECIAL PURPOSE, ELECTRICAL CX-11734/APM-239A	EA	1	
1	21	XDOHH 119163-2	119163-2	80249	CABLE ASSEMBLY, SPECIAL PURPOSE, ELECTRICAL CX-11735/APM-239A	EA	1	



ELONS002

Figure 2. Test Set, Transponder Set, AN/APM-239A, Interior View.

SECTION II		TM11-6625-842-24P						
(1)	(2)	(3)	(4)	(5)	(6)	(7)	(8)	
ILLUSTRATION					DESCRIPTION	USABLE ON CODE	QTY INC IN UNIT	
(A)	(B)	NATIONAL	PART	FSCM		U/M		
FIG	ITEM	STOCK	NUMBER					
NO	NO	NUMBER						
2	1		651014-3	80249	PLATE, IDENTIFICATION	EA	1	
2	2		651018	80249	CHART, CONTENTS	EA	1	
2	3	6625-00-802-7485	360087	80249	CASE, TEST SET CY-6477/APM-239A	EA	1	
2	4		564F4	70276	KEY, SOCKET HEADSCREW	EA	1	
2	5	6625-00-802-7455	119066-1	80249	TEST SET, TRANSPONDER TS-2681/APM-239A	EA	1	
2	6		651014-1	80249	PLATE, IDENTIFICATION	EA	1	
2	7	5920-00-280-5002	F03A250V10A	81349	FUSE, CARTRIDGE	EA	1	
2	8	5920-00-199-9498	F02A250V1/2A	81349	FUSE, CARTRIDGE	EA	1	
2	9	5920-00-280-4960	F02A250V2A	81349	FUSE, CARTRIDGE	EA	1	
2	10		332F4	70276	KEY, SOCKET HEADSCREW	EA	1	
2	11	5895-00-089-4403	C-6280(P)/APX	80058	CONTROL, TRANSPONDER SET OR	EA	1	
2	11	5895-00-782-0844	C-6280A(P)/APX	80058	CONTROL, TRANSPONDER SET	EA	1	

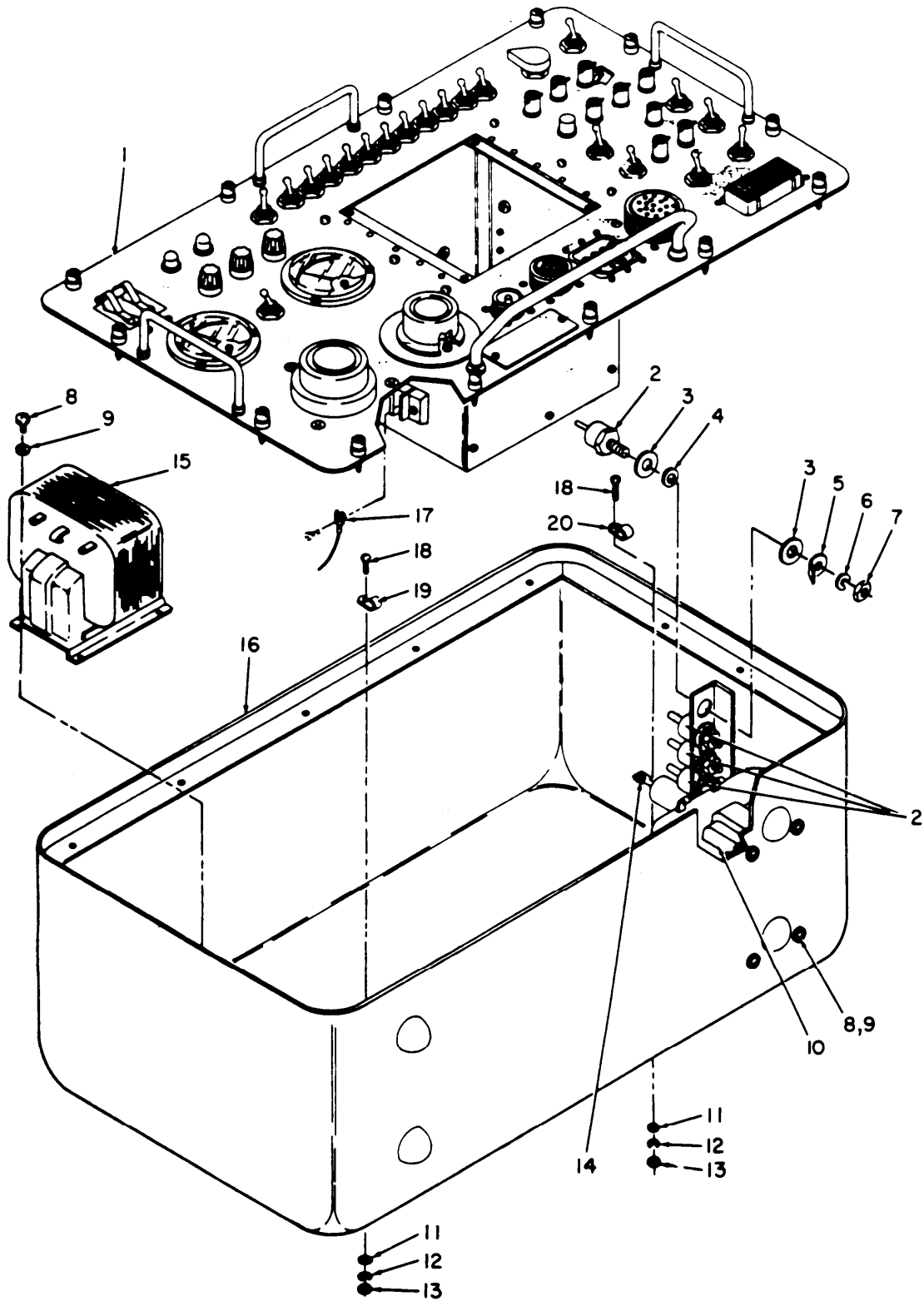

ELONS003

Figure 3. Test Set, Transponder Set TS-2681/AN-239A IL9066-1.

SECTION II (1) ILLUSTRATION (A) (B) FIG ITEM NO NO		(2) SMR CODE	(3) NATIONAL STOCK NUMBER	(4) PART NUMBER	(5) FSCM	TM11-6625-842-24P (6) DESCRIPTION	(7) USABLE ON CODE U/M	(8) QTY INC IN UNIT
						GROUP 01 TEST SET, TRANSPONDER SET		
						TS-2681/APM-239A 119066-1		
3	1	XDHHH		119067-1	80249	PANEL ASSEMBLY, TEST SET	EA	1
3	2	PAHZZ	5961-00-811-5799	JAN1N1202	81349	SEMICONDUCTOR DEVICE, DIODE	EA	4
3	3	XDHZZ		930129-8	80249	WASHER, NONMETALLIC	EA	8
3	4	XDHZZ		930120-2	80249	WASHER, NONMETALLIC	EA	4
3	5	PAHZZ	5940-00-681-8184	MS35431-8	96906	TERMINAL, LUG	EA	4
3	6	XDHZZ	5310-00-933-8120	MS35338-138	96906	WASHER, LOCK	EA	4
3	7	XDHZZ		NAS671C10	81349	NUT, PLAIN, HEXAGON	EA	4
3	8	XDHZZ	5305-00-059-3660	MS51958-64	96906	SCREW, MACHINE	EA	8
3	9	XDHZZ	5310-00-595-6772	MS15795-808	96906	WASHER, FLAT	EA	8
3	10	PAHZZ	5950-00-103-7009	690273	80249	REACTOR	EA	1
3	11	XDHZZ	5310-00-722-5998	MS15795-805	96906	WASHER, FLAT	EA	2
3	12	XDHZZ	5310-00-929-6395	MS35338-136	96906	WASHER, LOCK	EA	2
3	13	XDHZZ		MS16210-3	96906	NUT, PLAIN, HEXAGON	EA	2
3	14	XDHZZ		191P22492T16	56289	CAPACITOR, FIXED, PAPER	EA	1
3	15	PAHZZ	5950-00-013-7589	890360	80249	TRANSFORMER, POWER, STEP DOWN	EA	1
3	16	XDHZZ		360088	80249	CASE, TEST SET	EA	1
3	17	PAHZZ	5940-00-231-4430	41842	00779	TERMINAL, LUG	EA	6
3	18	PAHZZ	5305-00-054-6653	MS51957-29	96906	SCREW, MACHINE	EA	2
3	19	PAHZZ	5340-00-782-8737	HP4N	09922	CLAMP, LOOP	EA	1
3	20	PAHZZ	5340-00-619-7754	HP3N	09922	CLAMP, LOOP	EA	1



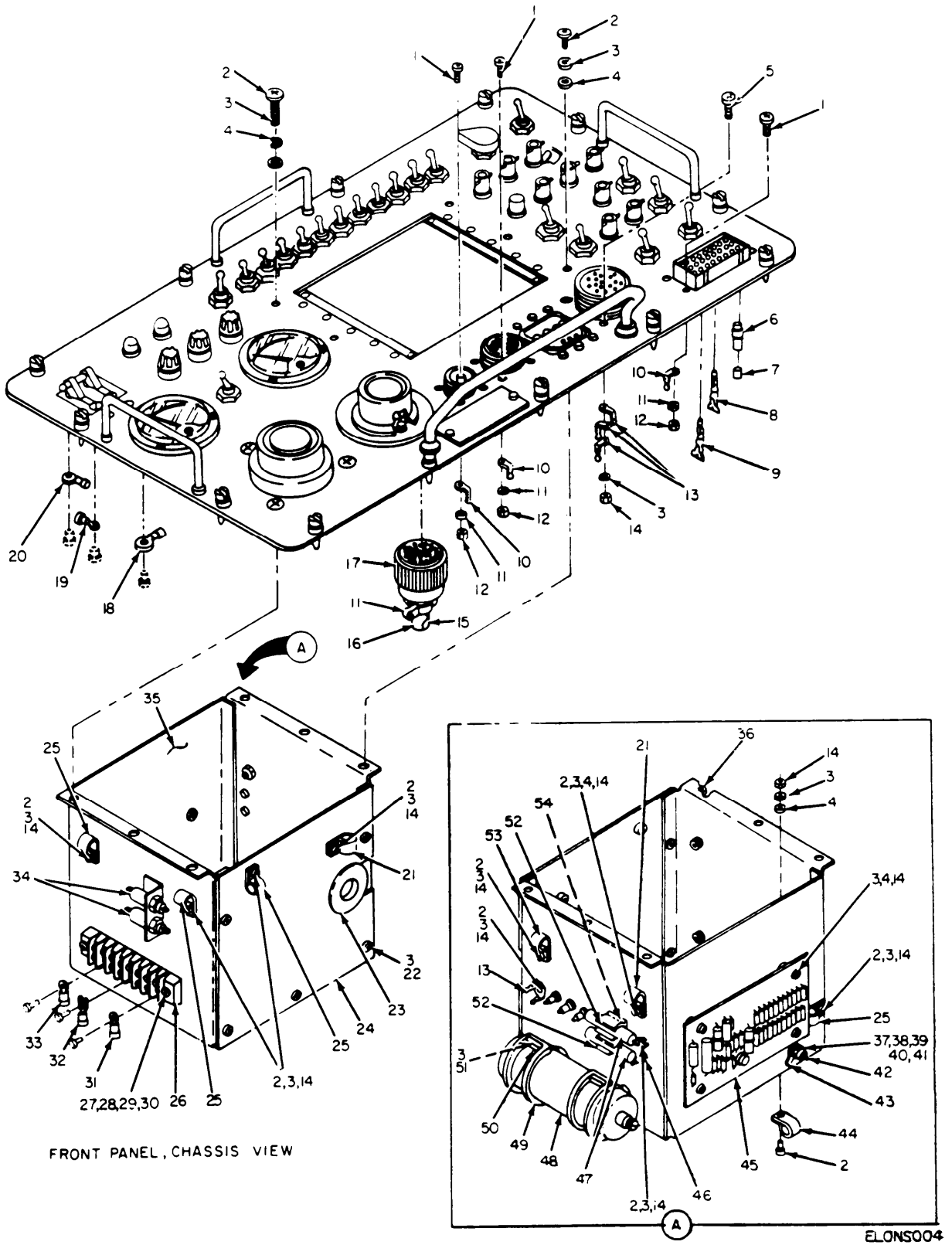

ELONSO04

Figure 4. Panel Assembly, Test Set 119067-1 (Sheet 1 of 2).

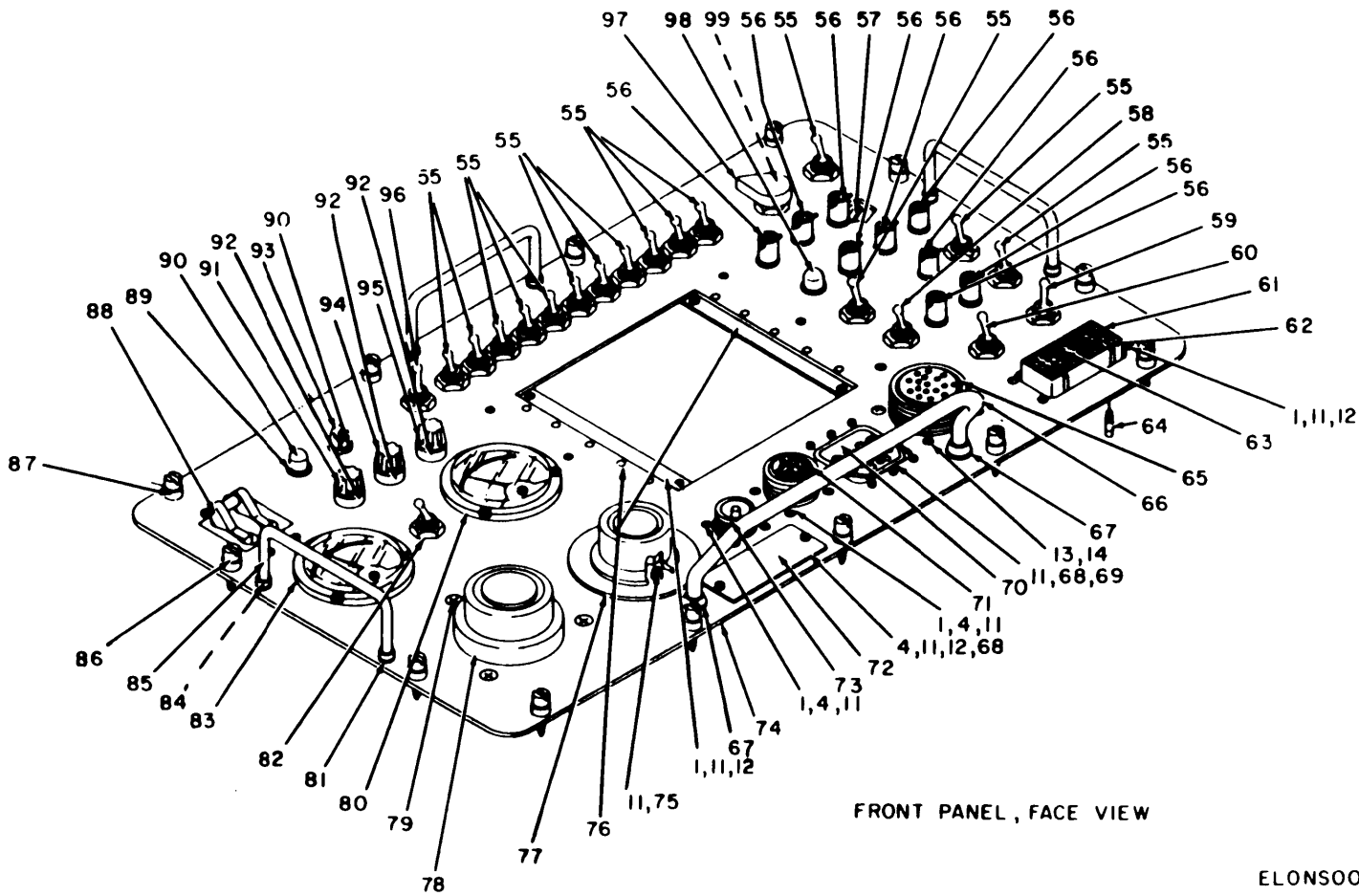

Figure 4. Panel Assembly, Test Set 119067-1 (Sheet 2 of 2).

ELONS005



SECTION II		TM11-6625-842-24P						
(1)	(2)	(3)	(4)	(5)	(6)	(7)	(8)	
ILLUSTRATION					DESCRIPTION		QTY	
(A)	(B)	NATIONAL	PART	FSCM		USABLE ON CODE	INC	
FIG	ITEM	STOCK	NUMBER			U/M	IN	
NO	NO	NUMBER	NUMBER		GROUP 0101 PANEL ASSEMBLY, TEST SET		UNIT	
					119067-1			
4	1	XDHZZ 5305-00-054-5650	MS51957-16	96906	SCREW, MACHINE	EA	12	
4	2	XDHZZ 5305-00-054-6653	MS51957-29	96906	SCREW, MACHINE	EA	15	
4	3	XDHZZ 5310-00-929-6395	MS35338-136	96906	WASHER, LOCK	EA	34	
4	4	XDHZZ 5310-00-722-5998	MS15795-805	96906	WASHER, FLAT	EA	22	
4	5	XDHZZ 5305-00-054-6654	MS51957-30	96906	SCREW, MACHINE	EA	4	
4	6	PAHZZ 5999-00-789-6272	1-331950-0	00779	CONTACT, ELECTRICAL	EA	10	
4	7	PAHZZ 5940-00-935-3508	1-332056-0	00779	FERRULE, RADIO FREQUENCY	EA	10	
4	8	PAHZZ 5999-00-918-4046	66100-1	00779	CONTACT, ELECTRICAL	EA	3	
4	9	PAHZZ 5935-00-909-8565	66104-1	00779	CONTACT, ELECTRICAL	EA	45	
4	10	XDHZZ	147-4-032BRASSHT	79963	TERMINAL, LUG	EA	3	
4	11	XDHZZ 5310-00-933-8118	MS35338-135	96906	WASHER, LOCK	EA	33	
4	12	XDHZZ	MS16210-2	96906	NUT, PLAIN, HEXAGON	EA	10	
4	13	XDHZZ	147-6-032BRASSHT	79963	TERMINAL, LUG	EA	5	
4	14	XDHZZ	MS16210-3	96906	NUT, PLAIN, HEXAGON	EA	13	
4	15	XDHZZ	AN3420-18A	88044	BUSHING, CABLE	EA	1	
4	16	XDHZZ 5365-00-598-5379	AN3420-16A	88044	BUSHING, CABLE	EA	1	
4	17	PAHZZ 5935-00-081-4340	MS24266R22B55S	96906	CONNECTOR, PLUG, ELECTRICAL	EA	1	
4	18	PAHZZ 5940-00-660-3631	MS25036-50	96906	TERMINAL, LUG	EA	2	
4	19	PAHZZ 5940-00-813-0698	MS25036-1	96906	TERMINAL, LUG	EA	3	
4	20	PAHZZ 5940-00-644-8713	MS25036-8	96906	TERMINAL, LUG	EA	6	
4	21	PAHZZ 5340-00-003-6667	HP8N	09922	CLAMP, LOOP	EA	2	
4	22	XDHZZ 5305-00-054-6651	MS51957-27	96906	SCREW, MACHINE	EA	9	
4	23	PAHZZ 5325-00-263-6648	MS35489-135	96906	GROMMET, RUBBER	EA	1	
4	24	XDHHH	119106-1	80249	COVER, TEST SET	EA	1	
4	25	PAHZZ 5340-00-975-1440	HP6N	09922	CLAMP, LOOP	EA	4	
4	26	PAHZZ 5940-00-503-4522	8T88	81349	TERMINAL BOARD	EA	1	
4	27	XDHZZ 5305-00-054-6672	MS51957-47	96906	SCREW, MACHINE	EA	2	
4	28	XDHZZ 5310-00-933-8119	MS35338-137	96906	WASHER, LOCK	EA	4	
4	29	XDHZZ 5310-00-880-5978	MS15795-807	96906	WASHER, FLAT	EA	2	
4	30	XDHZZ	MS16210-4	96906	NUT, PLAIN, HEXAGON	EA	2	
4	31	PAHZZ 5940-00-283-5280	MS25036-6	96906	TERMINAL, LUG	EA	10	
4	32	XDHZZ	41842	00779	TERMINAL, LUG	EA	1	
4	33	PAHZZ 5940-00-577-3711	MS25036-3	96906	TERMINAL, LUG	EA	6	
4	34	PAHZZ 5910-00-837-5109	CZ24BKF103	81349	FILTER, RADIO INTERFERENCE	EA	2	
4	35	XDHZZ	119095-1	80249	CHASSIS, ELECTRICAL EQUIPMENT	EA	1	
4	36	XDHZZ 5310-00-725-4719	CLS632-2	46384	NUT, SELF LOCKING	EA	15	
4	37	XDHZZ	NAS671C10	81349	NUT, PLAIN, HEXAGON	EA	1	
4	38	XDHZZ 5310-00-933-8120	MS35338-128	96906	WASHER, LOCK	EA	1	

SECTION II		TM11-6625-842-24P						
(1)	(2)	(3)	(4)	(5)	(6)	(7)	(8)	
ILLUSTRATION								
(A)	(B)	NATIONAL	PART	FSCM	DESCRIPTION	USABLE ON CODE	U/M	
FIG	ITEM	STOCK	NUMBER					
NO	NO	NUMBER	NUMBER				INC	
							IN	
							UNIT	
4	39	XDHZZ	5310-00-595-6772	MS15795-808	96906	WASHER, FLAT	EA	1
4	40	XDHZZ		930129-8	80249	WASHER, NONMETALLIC	EA	2
4	41	XDHZZ		930120-2	80249	WASHER, NONMETALLIC	EA	1
4	42	PAHZZ	5961-00-893-5938	JAN1N2982B	81349	SEMICONDUCTOR DEVICE, DIODE	EA	1
4	43	PAHZZ	5940-00-681-8184	MS35431-8	96906	TERMINAL, LUG	EA	1
4	44	PAHZZ	5340-00-619-7754	HP3N	09922	CLAMP, LOOP	EA	1
4	45	PAHHH	6625-00-103-2723	119064-1	80249	CIRCUIT CARD ASSEMBLY	EA	1
4	46	PAHZZ	5940-00-727-5243	SE099E02	81349	TERMINAL, STUD	EA	5
4	47	PAHZZ	5905-00-901-6988	RW68V270	81349	RESISTOR, FIXED, WIRE WOUND	EA	2
4	48	PAHZZ	5910-00-869-4855	CE71C681J	81349	CAPACITOR, FIXED, ELECTROLYTIC	EA	1
4	49	PAHZZ	5975-00-473-5595	N5	06229	STRAP, RETAINING	EA	2
4	50	PAHZZ	5340-00-946-9440	C3M	06229	STRAP, RETAINING	EA	2
4	51	XDHZZ	5305-00-054-6650	MS51957-26	96906	SCREW, MACHINE	EA	2
4	52	PAHZZ	5340-00-060-9031	MS28136-4	96906	CLIP, SPRING, TENSION	EA	2
4	53	PAHZZ	5340-00-337-8642	HP9N	09922	CLAMP, LOOP	EA	1
4	54	XDHZZ	5320-00-800-5704	MS16535-64	96906	RIVET, TUBULAR	EA	4
4	55	PAHZZ	5930-00-655-1515	MS35058-23	96906	SWITCH, TOGGLE	EA	15
4	56	PAHZZ	5935-00-853-7596	UG1094BU	81349	CONNECTOR, RECEPTACLE, ELECTRICAL	EA	9
4	57	XDHZZ		850186-1	80249	TERMINAL, LUG	EA	9
4	58	PAHZZ	5930-00-655-1513	MS35058-21	96906	SWITCH, TOGGLE	EA	1
4	59	PAHZZ	5930-00-581-3510	MS25126C3	96906	SWITCH, TOGGLE	EA	1
4	60	PAHZZ	5930-00-615-9376	MS35059-21	96906	SWITCH, TOGGLE	EA	1
4	61	PAHZZ	5935-00-063-9315	202795-1	00779	SHELL, ELECTRICAL CONNECTOR	EA	1
4	62	XDHZZ	5935-00-103-1756	202651-2	00779	INSERT, ELECTRICAL CONNECTOR	EA	3
4	63	XDHHH		117547-6	80249	CONNECTOR, RECEPTACLE, ELECTRICAL	EA	1
4	64	XDHZZ	3120-00-136-5638	51609-1	00779	BUSHING, COAXICON	EA	1
4	65	PAHZZ	5935-00-721-0493	MS3102A28-21S	96906	CONNECTOR, RECEPTACLE, ELECTRICAL	EA	1
4	66	XDHZZ		410125	80249	HANDLE, BOW	EA	1
4	67	XDHZZ		340297-3	80249	FERRULE, HANDLE	EA	2
4	68	XDHZZ	5305-00-054-5649	MS51957-15	96906	SCREW, MACHINE	EA	8
4	69	XDHZZ	5310-00-595-6211	MS15795-803	96906	WASHER, FLAT	EA	6
4	70	PAHZZ	5935-00-843-0144	94-52548-1	02660	CONNECTOR, RECEPTACLE, ELECTRICAL	EA	1
4	71	PAHZZ	5935-00-498-3620	MS3102A20-27S	96906	CONNECTOR, RECEPTACLE, ELECTRICAL	EA	1
4	72	XDHZZ		651014-2	80249	PLATE, IDENTIFICATION	EA	1
4	73	PAHZZ	5935-00-236-1087	MS3102A14S1P	96906	CONNECTOR, RECEPTACLE, ELECTRICAL	EA	1
4	74	XDHHH		119057-1	80249	PANEL, TEST SET	EA	1
4	75	XDHZZ	5305-00-770-2580	MS51959-16	96906	SCREW, MACHINE	EA	10
4	76	XDHZZ		341082	80249	STRIP, RECEPTACLE	EA	2
4	77	PAHZZ	5950-00-538-5662	890359-1	80249	TRANSFORMER, VARIABLE, POWER	EA	1
4	78	PAHZZ	5950-00-105-4030	890358-1	80249	TRANSFORMER, VARIABLE, POWER	EA	1

SECTION II (1) ILLUSTRATION (A) (B) FIG ITEM NO NO		(2) SMR CODE	(3) NATIONAL STOCK NUMBER	(4) PART NUMBER	(5) FSCM	TM11-6625-842-24P (6) DESCRIPTION	USABLE ON CODE	(7) U/M	(8) QTY INC IN UNIT
4	79	XDHZZ	5305-00-071-1322	MS51960-65	96906	SCREW, MACHINE		EA	6
4	80	PAHZZ	6625-00-928-5410	610072	80249	AMMETER		EA	1
4	81	PAHZZ	4730-00-912-2293	1212-2	71279	FERRULE, HANDLE		EA	6
4	82	PAHZZ	5930-00-655-1581	MS25068-23	96906	SWITCH, TOGGLE		EA	1
4	83	PAHZZ	6625-00-928-5412	610071	80249	VOLTMETER		EA	1
4	84	XDHZZ	5305-00-054-6669	MS51957-44	96906	SCREW, MACHINE		EA	6
4	85	PAHZZ	5340-00-916-4350	1292-2	71279	HANDLE, BOW		EA	3
4	86	PAHZZ	5305-00-721-5948	61C8SS0832-7	06540	SCREW, EXTERNALLY RELIEVED BODY		EA	13
4	87	XDHZZ		6312CSS0832	06540	NUT, PLAIN, CLINCH		EA	13
4	88	PAHZZ	5925-00-103-5075	PAM33MG6-6-250VA C400CPS	74193	CIRCUIT BREAKER		EA	1
4	89		6210-00-023-7031	LH74LC13WT	81349	LIGHT, INDICATOR		EA	1
4	90	PAOZZ	6240-00-892-4420	MS25252NE2D	96906	LAMP, GLOW		EA	2
4	91	PAOZZ	5920-00-280-5002	F03A250V10A	81349	FUSE, CARTRIDGE		EA	1
4	92	PAHZZ	5920-00-556-0144	FHN20G	81349	FUSEHOLDER		EA	3
4	93		6210-00-809-4274	CH74LC13RN	81349	LENS, INDICATOR LIGHT		EA	1
4	94	PAOZZ	5920-00-199-9498	F02A250V1/2D	81349	FUSE, CARTRIDGE		EA	1
4	95	PAOZZ	5920-00-280-4960	F02A250V2A	81349	FUSE, CARTRIDGE		EA	1
4	96	PAHZZ	5930-00-723-8020	MS25125DL	96906	SWITCH, TOGGLE		EA	1
4	97	PAOZZ	5355-00-899-9014	MS91528-2K4B	96906	KNOB		EA	1
4	98	PAOZZ	6210-00-084-3920	MS25256-2-327	96906	LIGHT, INDICATOR		EA	1
4	99	PAHZZ	5930-00-017-4707	841104	80249	SWITCH, ROTARY		EA	1

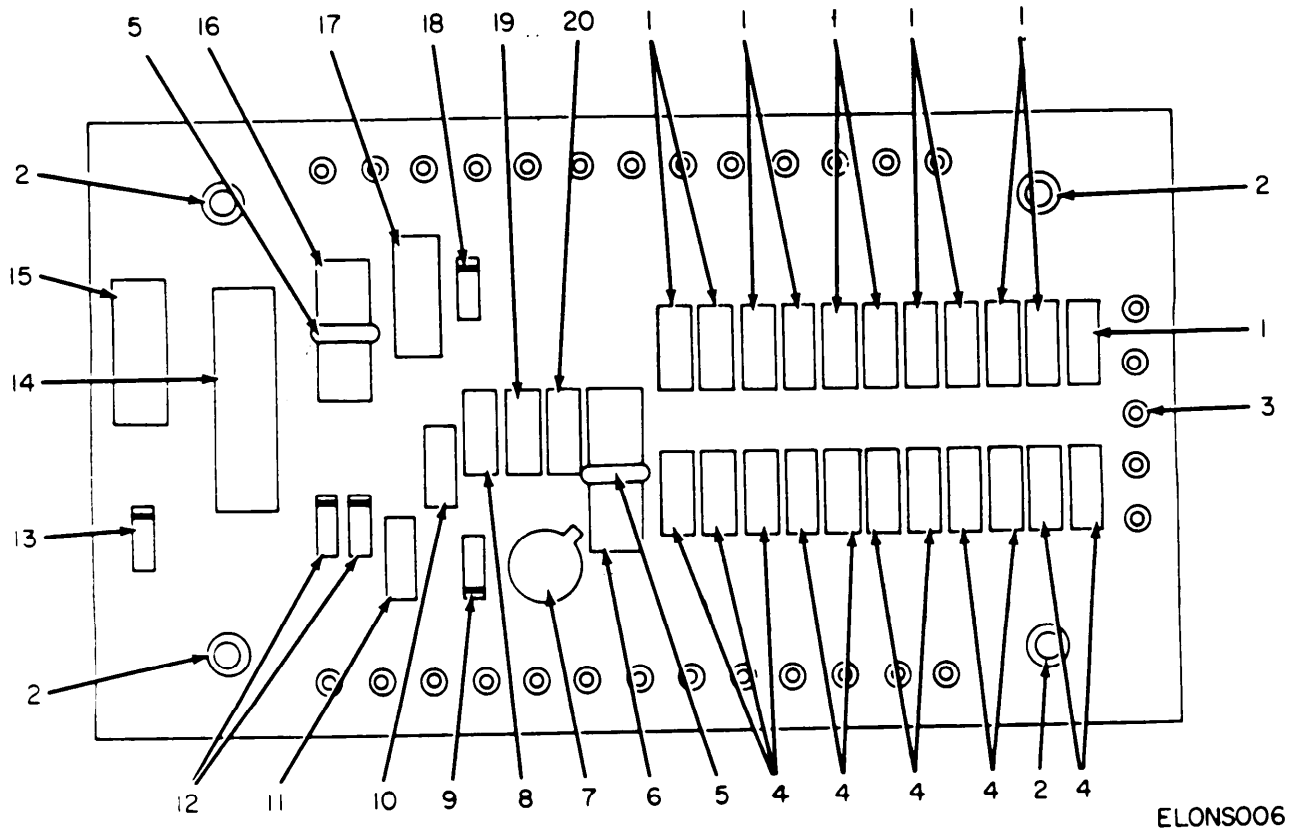
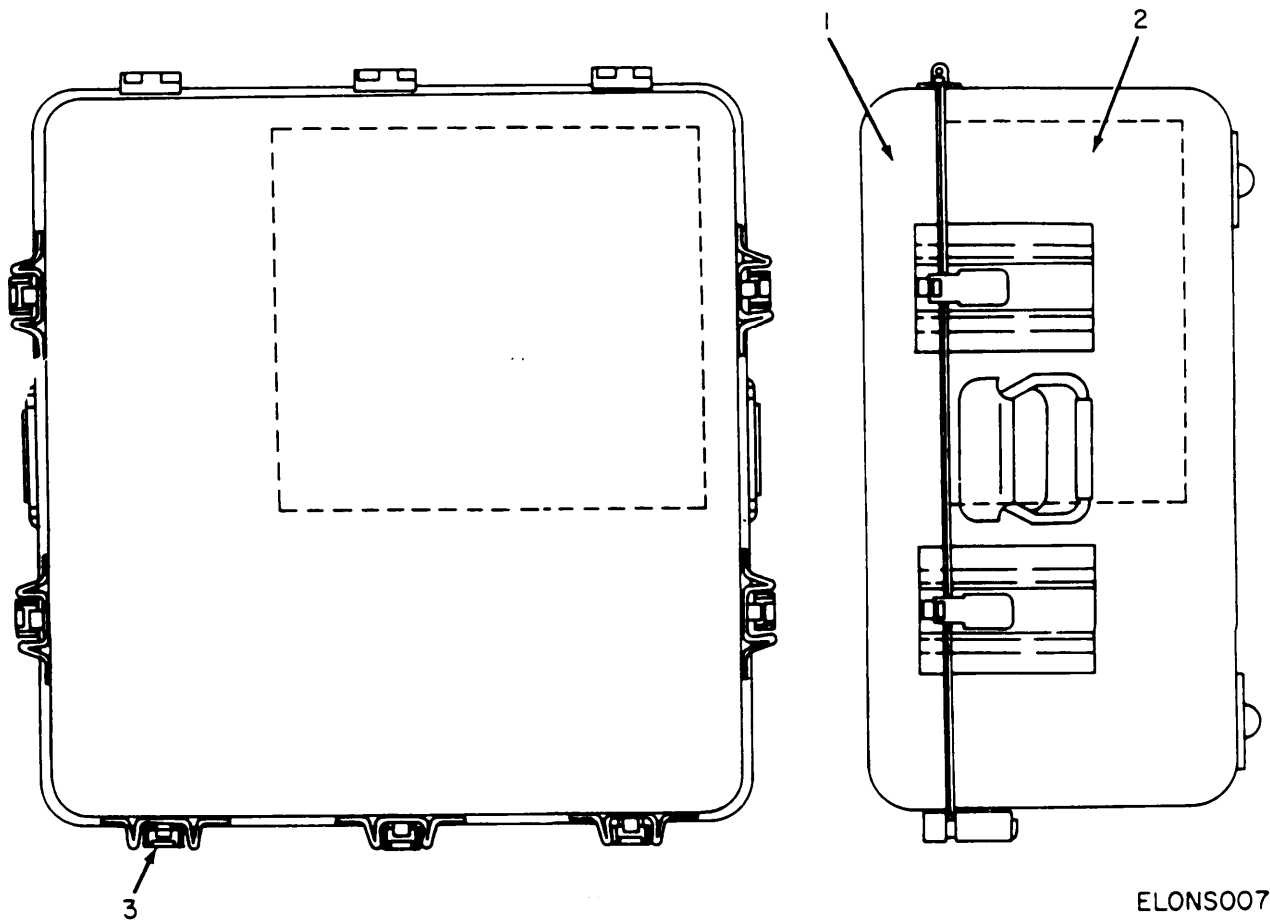

Figure 5. Circuit Card Assmnbly 119064-1.

SECTION II (1) ILLUSTRATION (A) (B) FIG ITEM NO NO		(2) SMR CODE	(3) NATIONAL STOCK NUMBER	(4) PART NUMBER	(5) FSCM	TM11-6625-842-24P (6) DESCRIPTION	(7) USABLE ON CODE U/M	(8) QTY INC IN UNIT
						GROUP 010101 CIRCUIT CARD ASSEMBLY 119064-1		
5	1	PAHZZ	5905-00-279-1751	RC20GF302J	81349	RESISTOR, FIXED, COMPOSITION	EA	11
5	2	XDHZZ		ST752895-112	80249	SPACER, SLEEVE	EA	4
5	3	XDHZZ		2034-2-05	71279	TERMINAL, STUD	EA	31
5	4	PAHZZ	5905-00-279-1867	RC20GF114J	81349	RESISTOR, FIXED, COMPOSITION	EA	11
5	5	PAHZZ	5330-00-873-3450	2829-75-1	98159	STRAP, RUBBER	EA	2
5	6	XDHZZ		CS13BG226K	81349	CAPACITOR, FIXED, ELECTROLYTIC	EA	1
5	7	PAHZZ	5961-00-949-1432	JAN2N2219A	81349	TRANSISTOR	EA	1
5	8	PAHZZ	5905-00-279-1757	RC20GF152J	81349	RESISTOR, FIXED, COMPOSITION	EA	1
5	9	PAHZZ	5961-00-842-9864	JAN1N914	81349	SEMICONDUCTOR DEVICE, DIODE	EA	1
5	10	PAHZZ	5905-00-279-3513	RC20GF221J	81349	RESISTOR, FIXED, COMPOSITION	EA	1
5	11	PAHZZ	5905-00-279-3516	RC20GF910J	81349	RESISTOR, FIXED, COMPOSITION	EA	1
5	12	PAHZZ	5961-00-957-6865	JAN1N3611	81349	SEMICONDUCTOR DEVICE, DIODE	EA	2
5	13	PAHZZ	5961-00-729-5499	JAN1N486B	81349	SEMICONDUCTOR DEVICE, DIODE	EA	1
5	14	PAHZZ	5905-00-061-0739	RW67G101	81349	RESISTOR, FIXED, WIRE WOUND	EA	1
5	15	XDHZZ		RN70C1722D	81349	RESISTOR, FIXED, FILM	EA	1
5	16	PAHZZ	5910-00-783-5213	CS13BF336K	81349	CAPACITOR, FIXED, ELECTROLYTIC	EA	1
5	17	PAHZZ	5905-00-141-1311	RC32G202JR	81349	RESISTOR, FIXED, COMPOSITION	EA	1
5	18	PAHZZ	5961-00-852-7549	JAN1N754A	81349	SEMICONDUCTOR DEVICE, DIODE	EA	1
5	19	PAHZZ	5905-00-192-3973	RC20GF471J	81349	RESISTOR, FIXED, COMPOSITION	EA	1
5	20	PAHZZ	5910-00-777-6897	CS13BC475K	81349	CAPACITOR, FIXED, ELECTROLYTIC	EA	1



ELONS007

Figure 6. Case, Test Set C7-6477/APM-239A 360087.

(1) ILLUSTRATION		(2)	(3)	(4)	(5)	(6) DESCRIPTION	(7)	(8)
(a) FIG NO	(b) ITEM NO	SMR CODE	NATIONAL STOCK NUMBER	PART NUMBER	FSCM	VISIBLE ON COVER	QTY	INC IN UNIT
						<b>GROUP 0102 CASE, TEST SET CY-6477/APM-239A</b>		
						<b>360087</b>		
6	1	XDNZZ		360087-2	80249	COVER ASSEMBLY	EA	1
6	2	XDNZZ	6625-00-802-7485	360087-1	80249	CASE	EA	1
6	3	PRMZZ	4920-00-730-3481	ZSP6-602	98376	VALVE, RELIEF	EA	1

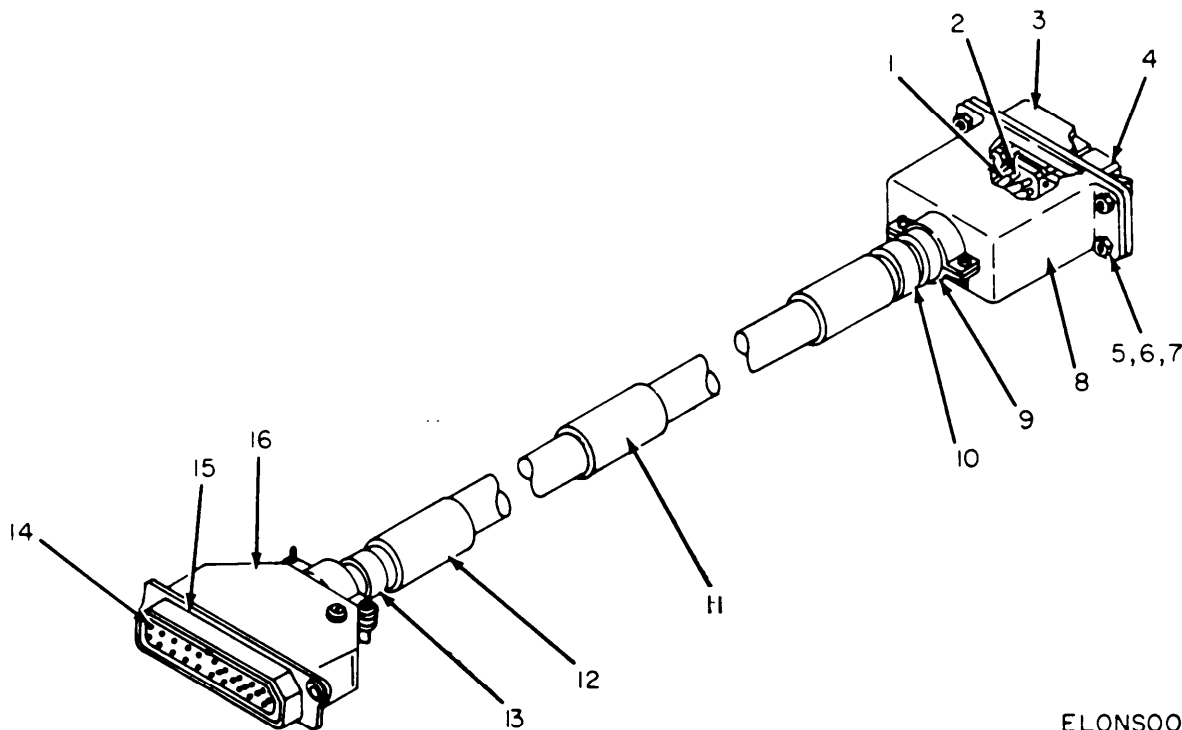

ELONSO08

Figure 7. Cable Assembly, Special Purpose, Electrical CX-10905/APM-239A.

(1) ILLUSTRATION		(2)	(3)	(4)	(5)	(6) DESCRIPTION	(7)	(8)
(a) F-G NO	(d) ITEM NO	SMR CODE	NATIONAL STOCK NUMBER	PART NUMBER	FSCM	TABLE CODE	QTY IN	UNIT
						<b>GROUP 02 CABLE ASSEMBLY, SPECIAL PURPOSE.</b>		
						<b>ELECTRICAL CX-10905/APM-239A</b>		
7	1	PAMZZ	5940-00-935-3508	1-332056-0	00779	FERRULE, RADIO FREQUENCY CABLE, GROUNDING	EA	10
7	2	PAMZZ	5999-00-103-7371	331952-0	00779	CONTACT, ELECTRICAL	EA	10
7	3	PAMZZ	5935-00-103-1755	202287-1	00779	SHELL, ELECTRICAL CONNECTOR	EA	1
7	4	PAMZZ	5935-00-106-3803	202650-2	07799	INSERT, ELECTRICAL CONNECTOR	EA	3
7	5	XDMZZ	5305-00-054-5650	MS51957-16	96906	SCREW, MACHINE	EA	4
7	6	XDMZZ	5310-00-933-0110	MS35330-135	96906	WASHER, LOCK	EA	4
7	7	XDMZZ		MS16210-2	96906	NUT, PLAIN, HEXAGON	EA	4
7	8	PAMZZ	5935-00-103-7370	1-202301-0	00779	SHIELD, ELECTRICAL CONNECTOR	EA	1
7	9	PAMZZ	5365-00-598-5379	AN3420-16A	88044	BUSHING, CABLE ADAPTER	EA	1
7	10	XDMZZ		651023-4	80249	BAND MARKER, CABLE	EA	1
7	11	XDMZZ		61029-42	80249	BAND MARKER, CABLE	EA	1
7	12	XDMZZ		651023-23	80249	BAND MARKER, CABLE	EA	1
7	13	XDMZZ		651023-5	80249	BAND MARKER, CABLE	EA	1
7	14	PAMZZ	5999-00-400-1534	66102-1	00779	CONTACT, ELECTRICAL	EA	40
7	15	PAMZZ	5935-00-841-3386	DPJ59C10-345B	71468	CONNECTOR, PLUG, ELECTRICAL	EA	1
7	16	PAMZZ	5935-00-931-6831	5428-1	07418	SHIELD, ELECTRICAL CONNECTOR	EA	1

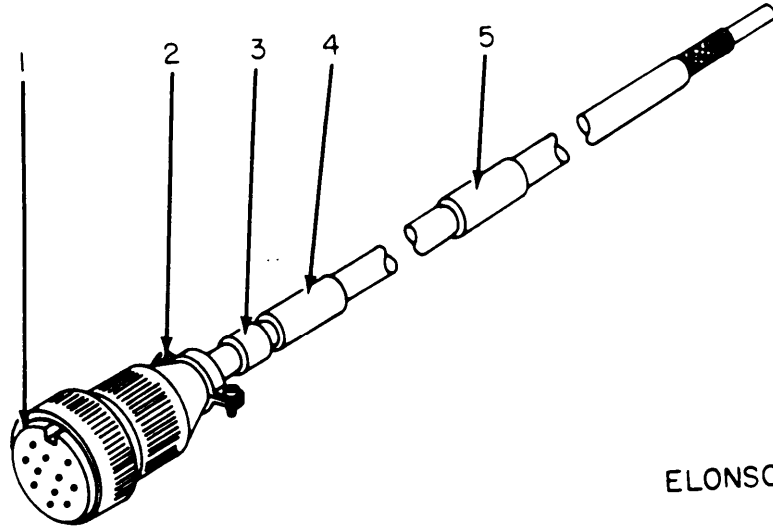

ELONS009

Figure 8. Cable Assembly, Power, Electrical CX-10926/APM-239A.

(1) ILLUSTRATION		(2)	(3)	(4)	(5)	(6) DESCRIPTION	(7)	(8)
(B) FIG NO	(D) ITEM NO	SMR CODE	NATIONAL STOCK NUMBER	PART NUMBER	FSCM		QTY INC IN UNIT	
						GROUP 03 CABLE ASSEMBLY, POWER, ELECTRICAL CX-10926/APM-239A		
0	1	PAMZZ	5935-00-244-9919	MS3106A145-15	96906	CONNECTOR, PLUG, ELECTRICAL	EA	1
0	2	PAMZZ	5935-00-280-2195	MS3057-6A	96906	CLAMP, ELECTRICAL CONNECTOR	EA	1
0	3	XDMZZ		651023-8	80249	BAND MARKER, CABLE	EA	1
0	4	XDMZZ		651023-7	80249	BAND MARKER, CABLE	EA	1
0	5	XDMZZ		651023-6	80249	BAND MARKER, CABLE	EA	1



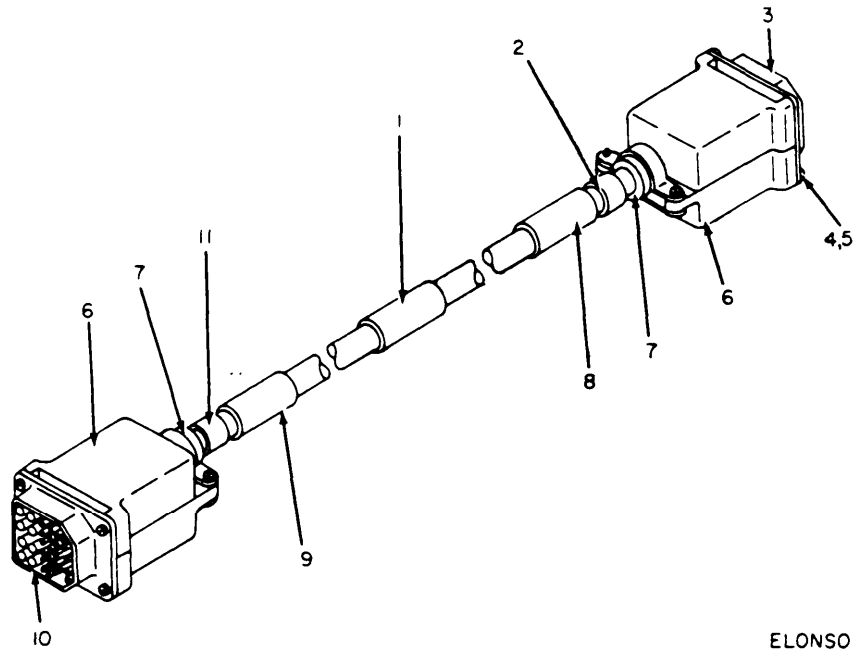
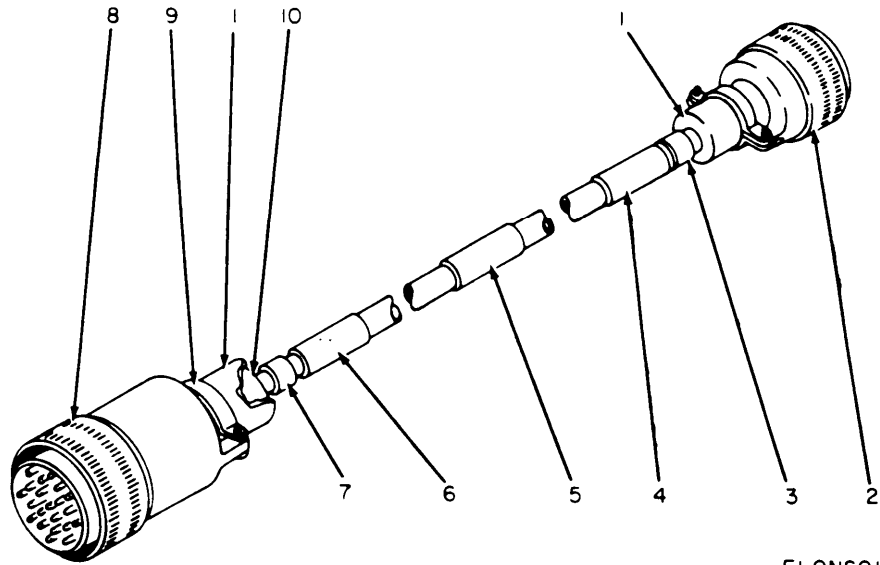

Figure 9. Cable Assembly, Special Purpose, Electrical CX-10908/APM-239A.

(1) ILLUSTRATION		(2)	(3)	(4)	(5)	(6)	(7)
(a) FIG NO	(b) ITEM NO	SMR CODE	NATIONAL STOCK NUMBER	PART NUMBER	PSCN	DESCRIPTION	QTY INC N U M B E R
<b>GROUP 04 CABLE ASSEMBLY, SPECIAL PURPOSE, ELECTRICAL CX-10908/APM-239A</b>							
9	1	XDMZZ		651023-25	80249	BAND MARKER, CABLE	EA 1
9	2	XDMZZ		651023-11	80249	BAND MARKER, CABLE	EA 1
9	3	PAMZZ	5935-00-103-7374	94-62540-1	02660	CONNECTOR, PLUG, ELECTRICAL	EA 1
9	4	XDMZZ	5305-00-054-5650	M551957-31	96906	SCREW, MACHINE	EA 8
9	5	XDMZZ	5305-00-933-8118	M535330-105	96906	WASHER, LOCK	EA 8
9	6	PAMZZ	5935-00-109-9827	5283-2-1	07418	SHIELD, ELECTRICAL CONNECTOR	EA 2
9	7	PAMZZ	5365-00-598-5287	AN3420-12A	88044	BUSHING, CABLE ADAPTER	EA 2
9	8	XDMZZ		651023-24	80249	BAND MARKER, CABLE	EA 1
9	9	XDMZZ		651023-8	80249	BAND MARKER, CABLE	EA 1
9	10	PAMZZ	5935-00-843-0144	94-52540-1	02660	CONNECTOR, PLUG, ELECTRICAL	EA 1
9	11	XDMZZ		651023-24	80249	BAND MARKER, CABLE	EA 1



ELONSO11

Figure 10. Cable Assembly, Special Purpose, Electrical CX-10909/APM-239A.

(1)	(2)	(3)	(4)	(5)	(6)	(7)	(8)
ILLUSTRATION					DESCRIPTION		
(9)	(10)		NATIONAL				
FIG	ITEM	SMR	STOCK	PART	FSCM		QTY
NO	NO	CODE	NUMBER	NUMBER			INC
							UN
							UNT
GROUP 05 CABLE ASSEMBLY, SPECIAL PURPOSE.							
ELECTRICAL CX-10909/APM-239A							
10	1	PANZZ	5365-00-598-5394	AN3420-8A	88044	BUSHING, CABLE ADAPTER	EA 2
10	2	PANZZ	5935-00-782-7266	MS2466R12B12	96906	CONNECTOR, PLUG, ELECTRICAL	EA 1
10	3	XDMZZ		651023-31	80249	BAND MARKER, CABLE	EA 1
10	4	XDMZZ		651023-28	80249	BAND MARKER, CABLE	EA 1
10	5	XDMZZ		651023-29	80249	BAND MARKER, CABLE	EA 1
10	6	XDMZZ		651023-27	80249	BAND MARKER, CABLE	EA 1
10	7	XDMZZ		651023-30	80249	BAND MARKER, CABLE	EA 1
10	8	PANZZ	5935-00-259-0071	MS3106A20-27P	96906	CONNECTOR, PLUG, ELECTRICAL	EA 1
10	9	PANZZ	5935-00-223-0572	MS3057-12A	96906	CLAMP, ELECTRICAL CONNECTOR	EA 1
10	10	PANZZ	5365-00-598-5287	AN3420-12A	88044	BUSHING, CABLE ADAPTER	EA 1

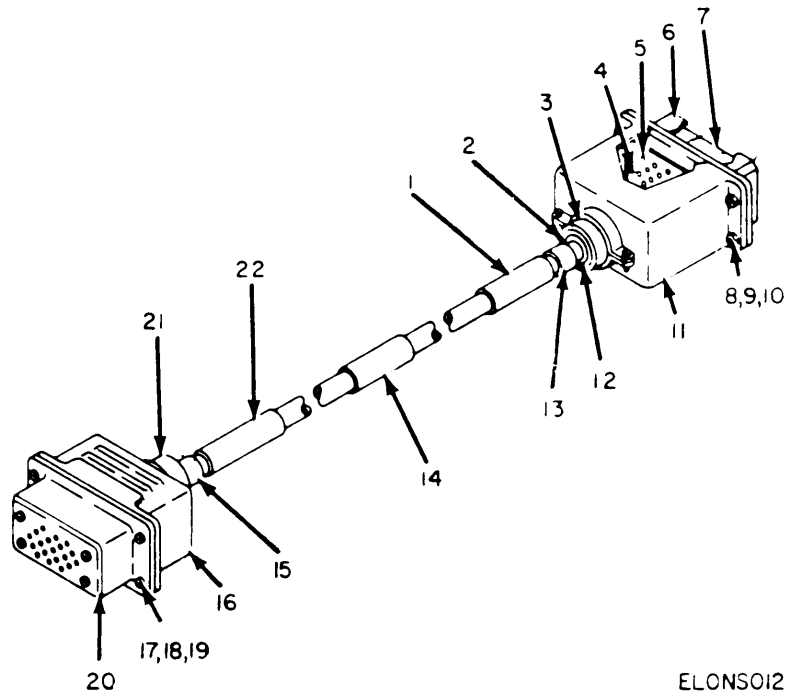

ELONSOI2

Figure 11. Cable Assembly, Special Purpose, Electrical CX-10907/APM-239A.

(1)	(2)	(3)	(4)	(5)	(6)	(7)	(8)
ILLUSTRATION					DESCRIPTION		QTY
FIG NO	ITEM NO	SMR CODE	NATIONAL STOCK NUMBER	PART NUMBER	FSCM	UNLESS OTHERWISE SPECIFIED	INC IN UNIT
GROUP 06 CABLE ASSEMBLY, SPECIAL PURPOSE,							
ELECTRICAL CX-10907/APM-239A							
11	1	XDMZZ		651023-6	80249	BAND MARKER, CABLE	EA 1
11	2	PAMZZ	5365-00-598-5379	AN3420-16A	88044	BUSHING, CABLE ADAPTER	EA
11	3	XDMZZ		AN3420-18A	88044	BUSHING, CABLE ADAPTER	EA 1
11	4	PAMZZ	5935-00-910-9177	66098-1	00779	CONTACT, ELECTRICAL	EA 2
11	5	PAMZZ	5999-00-400-1534	66102-1	00779	CONTACT, ELECTRICAL	EA 28
11	6	PAMZZ	5935-00-103-1755	202287-1	00779	SHIELD, ELECTRICAL CONNECTOR	EA 1
11	7	PAMZZ	5935-00-104-3803	202650-2	00779	INSERT, ELECTRICAL, CONNECTOR	EA 3
11	8	XDMZZ	5305-00-054-5650	MS51957-16	96906	SCREW, MACHINE	EA 4
11	9	XDMZZ	5310-00-935-8118	MS35338-135	96906	WASHER, LOCK	EA 4
11	10	XDMZZ		MS16210-2	96906	NUT, PLAIN, HEXAGON	EA 4
11	11	PAMZZ	5935-00-103-7370	1-202301-0	00779	SHIELD, ELECTRICAL CONNECTOR	EA 1
11	12	XDMZZ	5365-00-598-5379	AN3420-16A	88044	BUSHING, CABLE ADAPTER	EA 1
11	13	XDMZZ		651023-8	80249	BAND MARKER, CABLE	EA 1
11	14	XDMZZ		651023-33	80249	BAND MARKER, CABLE	EA 1
11	15	XDMZZ		651023-26	80249	BAND MARKER, CABLE	EA 1
11	16	PAMZZ	5935-00-518-6983	DPD33-11612	71468	SHIELD, ELECTRICAL CONNECTOR	EA 1
11	17	XDMZZ	5305-00-765-4352	MS51959-31	96906	SCREW, MACHINE	EA 4
11	18	XDMZZ	5310-00-929-6395	MS35338-136	96906	WASHER, LOCK	EA 4
11	19	XDMZZ		MS16210-3	96906	NUT, PLAIN, HEXAGON	EA 4
11	20	PAMZZ	5935-00-553-2949	DPD45-3351L	71468	CONNECTOR, PLUG, ELECTRICAL	EA 1
11	21	PAMZZ	5369-00-663-2125	AN3420-10A	88044	BUSHING, CABLE ADAPTER	EA
11	22	XDMZZ		651023-32	80249	BAND MARKER, CABLE	EA 1

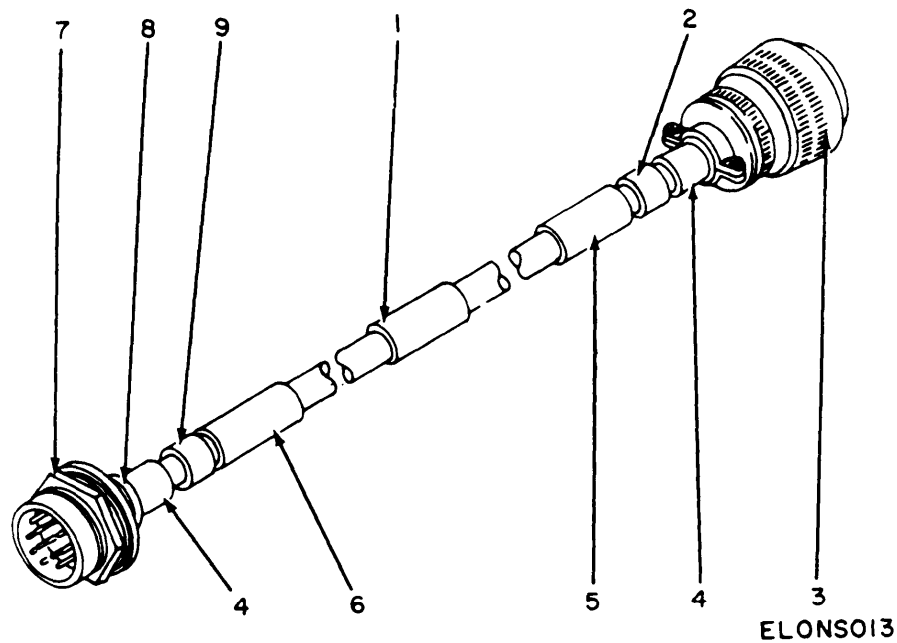

Figure 12. Cable Assembly, Special Purpose, Electrical CX-10910/APM-239A.

ILLUSTRATION		(1)	(2)	(3)	(4)	(5)	(6)	(7)	(8)
FIG. NO.	ITEM NO.	SMR CODE	NATIONAL STOCK NUMBER	PART NUMBER	FSCM	DESCRIPTION	REL. DIS. CODE	QTY	INC. IN UNIT
<b>GROUP 07 CABLE ASSEMBLY, SPECIAL PURPOSE, ELECTRICAL CX-10910/APM-239A</b>									
12	1	XDHZZ		651023-36	80249	BAND MARKER, CABLE		EA	1
12	2	XDHZZ		651023-34	80249	BAND MARKER, CABLE		EA	1
12	3	PAHZZ	5935-00-717-2591	MS3116F18-325	96906	CONNECTOR, PLUG, ELECTRICAL		EA	1
12	4	PAHZZ	5365-00-598-5379	AN3420-16A	88044	BUSHING, CABLE ADAPTER		EA	2
12	5	XDHZZ		651023-35	80249	BAND MARKER, CABLE		EA	1
12	6	XDHZZ		651023-17	80249	BAND MARKER, CABLE		EA	1
12	7	PAHZZ	5935-00-702-9065	MS2426SR22059P	96906	CONNECTOR, PLUG, ELECTRICAL		EA	1
12	8	XDHZZ		AN3420-18A	88044	BUSHING, CABLE ADAPTER		EA	1
12	9	XDHZZ		651023-18	80249	BAND MARKER, CABLE		EA	1

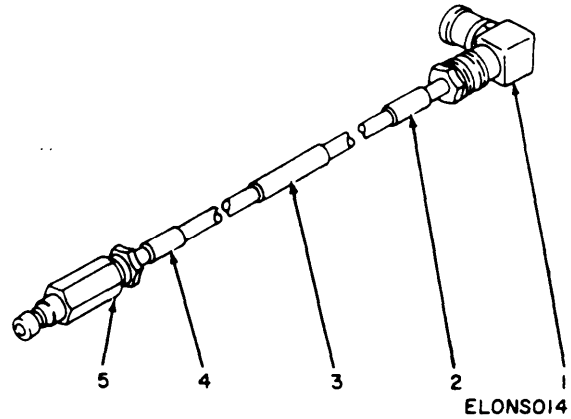

Figure 13. Cable Assembly, Radio Frequency CG-3470/APM-239A.

(1) ILLUSTRATION		(2)	(3)	(4)	(5)	(6) DESCRIPTION	(7)	(8)
(B) FIG NO	(D) ITEM NO	SMR CODE	NATIONAL STOCK NUMBER	PART NUMBER	FSCM		CABLE ON CODE	QTY INC IN UNIT
<b>GROUP 00 CABLE ASSEMBLY, RADIO FREQUENCY CG-3470/APM-239A</b>								
13	1	PANZZ	5935-00-937-2782	51-011-0000	98291	CONNECTOR, PLUG, ELECTRICAL		EA 1
13	2	XDMZZ		651023-44	80249	BAND MARKER, CABLE		EA 1
13	3	XDMZZ		651023-43	80249	BAND MARKER, CABLE		EA 1
13	4	XDMZZ		651023-45	80249	BAND MARKER, CABLE		EA 1
13	5	PANZZ	5935-00-929-7108	51-008-0000	98291	CONNECTOR, PLUG, ELECTRICAL		EA 1

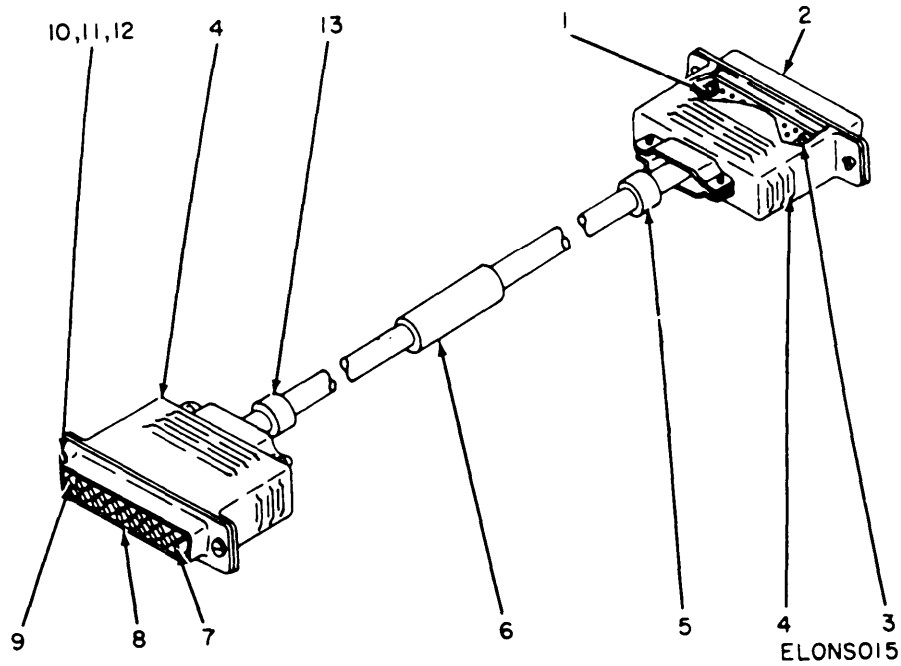

Figure 14. Cable Assembly, Special Purpose, Electrical CX-11734/APM-239A.

(1) ILLUSTRATION (A) FIG NO	(2) (B) ITEM NO	(3) SMR CODE	(4) NATIONAL STOCK NUMBER	(5) PART NUMBER	(6) FSCM	(7) DESCRIPTION	(8) QTY INC IN U M UNIT
GROUP OF CABLE ASSEMBLY, SPECIAL PURPOSE, ELECTRICAL CX-11734/APM-239A							
14	1	PAHZZ	5999-00-910-5054	DM51155	91146	CONTACT, ELECTRICAL	EA 1
14	2	PAHZZ	5935-00-949-5647	DM17M2P	91146	CONNECTOR, PLUG, ELECTRICAL	EA 1
14	3	PAHZZ		DM53742-5001	91146	CONTACT, ELECTRICAL	EA 1
14	4	PAHZZ	5935-00-722-4350	DB24659	71468	SHIELD, ELECTRICAL CONNECTOR	EA 2
14	5	XDMZZ		651023-26	80249	BAND MARKER, CABLE	EA 1
14	6	XDMZZ		651023-46	80249	BAND MARKER, CABLE	EA 1
14	7	PAHZZ	5999-00-878-4714	DM53740-5001	91146	CONTACT, ELECTRICAL	EA 1
14	8	PAHZZ	5935-00-983-7040	DMF17M2S	91146	CONNECTOR, PLUG, ELECTRICAL	EA 1
14	9	PAHZZ	5999-00-089-9520	DM51157	91146	CONTACT, ELECTRICAL	EA 1
14	10	XDMZZ	5305-00-054-5637	MS51957-3	96906	SCREW, MACHINE	EA 4
14	11	XDMZZ		MS35338-134	96906	WASHER, LOCK	EA 4
14	12	XDMZZ	5310-00-912-4294	MSA71C2	80205	NUT, PLAIN, HEXAGON	EA 4
14	13	XDMZZ		651023-8	80249	BAND MARKER, CABLE	EA 1

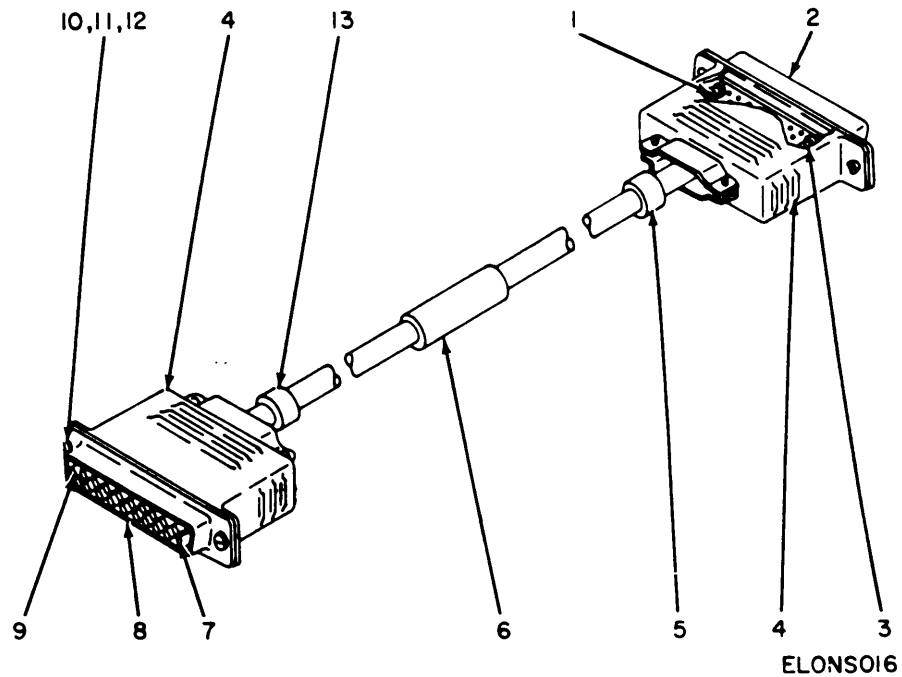

Figure 15. Cable Assembly, Special Purpose, Electrical CX-11735/APM-239A.

(1) ILLUSTRATION		(2)	(3)	(4)	(5)	(6) DESCRIPTION	(7) QTY INC IN	(8) UNIT
(a) FIG NO	(b) ITEM NO	SMR CODE	NATIONAL STOCK NUMBER	PART NUMBER	FSCM	UNLESS OTHERWISE SPECIFIED		
<b>GROUP 10 CABLE ASSEMBLY, SPECIAL PURPOSE, ELECTRICAL CX-11735/APM-239A</b>								
15	1	KDMZZ		DM51155	91146	CONTACT, ELECTRICAL	EA	1
15	2	PAMZZ	5935-00-153-8455	DM17W29	71268	CONNECTOR, PLUG, ELECTRICAL	EA	1
15	3	PAMZZ		DM53742-9001	91146	CONTACT, ELECTRICAL	EA	1
15	4	PAMZZ	5935-00-722-4350	DB24659	71468	SHIELD, ELECTRICAL CONNECTOR	EA	2
15	5	KDMZZ		651023-26	80249	BAND MARKER, CABLE	EA	1
15	6	KDMZZ		651023-47	80249	BAND MARKER, CABLE	EA	1
15	7	PAMZZ	5999-00-878-4714	DM53740-9001	91146	CONTACT, ELECTRICAL	EA	1
15	8	PAMZZ	5935-00-983-7848	DM17W25	91146	CONNECTOR, PLUG, ELECTRICAL	EA	1
15	9	KDMZZ		DM51157	91146	CONTACT, ELECTRICAL	EA	1
15	10	KDMZZ	5305-00-054-5637	MS1957-3	94906	SCREW, MACHINE	EA	4
15	11	KDMZZ		MS3938-134	94906	WASHER, LOCK	EA	4
15	12	KDMZZ	5310-00-812-4294	NAS671C2	80285	NUT, PLAIN, HEXAGON	EA	4
15	13	KDMZZ		651023-8	80249	BAND MARKER, CABLE	EA	1

NOTE: LATEST NATIONAL STOCK NUMBER AND PART NUMBER ASSIGNMENTS ARE INCLUDED AT END OF INDEX

STOCK NUMBER	FIGURE NO	ITEM NO	STOCK NUMBER	FIGURE NO	ITEM NO
5340-00-003-6667	4	21	5920-00-556-0144	4	92
5950-00-013-7589	3	15	5935-00-557-9862	1	11
5930-00-017-4707	4	99	5940-00-577-3711	4	33
5120-00-020-0176	1	3	5930-00-581-3510	4	59
6210-00-023-7031	4	89	5310-00-595-6211	4	69
5305-00-054-5637	14	10	5310-00-595-6772	3	9
5305-00-054-5637	15	10	5310-00-595-6772	4	39
5305-00-054-5649	4	68	5365-00-598-5287	9	7
5305-00-054-5650	4	1	5365-00-598-5287	10	10
5305-00-054-5650	7	5	5365-00-598-5379	4	16
5305-00-054-5650	9	4	5365-00-598-5379	7	9
5305-00-054-5650	11	8	5365-00-598-5379	11	2
5305-00-054-6650	4	51	5365-00-598-5379	11	12
5305-00-054-6651	4	22	5365-00-598-5379	12	4
5305-00-054-6653	3	18	5365-00-598-5394	10	1
5305-00-054-6653	4	2	5930-00-615-9376	4	60
5305-00-054-6654	4	5	5340-00-619-7754	3	20
5305-00-054-6669	4	84	5340-00-619-7754	4	44
5305-00-054-6672	4	27	5940-00-644-8713	4	20
5305-00-059-3660	3	8	5930-00-655-1513	4	58
5340-00-060-9031	4	52	5930-00-655-1515	4	55
5905-00-061-0739	5	14	5930-00-655-1581	4	82
5935-00-063-9315	4	61	5940-00-660-3631	4	18
5305-00-071-1322	4	79	5365-00-663-2125	11	21
5935-00-081-4340	4	17	5940-00-681-8184	3	5
6210-00-084-3920	4	98	5940-00-681-8184	4	43
5999-00-089-9520	14	9	5935-00-702-9065	12	7
5935-00-103-1755	7	3	5935-00-717-2591	12	3
5935-00-103-1755	11	6	5935-00-721-0493	4	65
5935-00-103-1756	4	62	5305-00-721-5948	4	86
6625-00-103-2723	4	45	5935-00-722-4350	14	4
5925-00-103-5075	4	88	5935-00-722-4350	15	4
5950-00-103-7009	3	10	5310-00-722-5998	3	11
5935-00-103-7370	7	8	5310-00-722-5998	4	4
5935-00-103-7370	11	11	5930-00-723-8020	4	96
5999-00-103-7371	7	2	5310-00-725-4719	4	36
5935-00-103-7374	9	3	5940-00-727-5243	4	46
5950-00-105-4030	4	78	5961-00-729-5499	5	13
5935-00-106-3803	7	4	4920-00-730-3481	6	3
5935-00-106-3803	11	7	5305-00-765-4352	11	17
6625-00-107-7968	1	7	5305-00-770-2580	4	75
6625-00-107-7982	1	5	5910-00-777-6897	5	20
6625-00-107-7987	1	10	5935-00-782-7266	10	2
6625-00-107-8009	1	9	5340-00-782-8737	3	19
6625-00-107-8013	1	6	5910-00-783-5213	5	16
6625-00-107-8126	1	8	5999-00-789-6272	4	6
6625-00-109-6133	1	13	5320-00-800-5704	4	54
5935-00-109-9827	9	6	6625-00-802-7425	1	1
3120-00-136-5638	4	64	6625-00-802-7455	2	5
5905-00-192-3973	5	19	6625-00-802-7485	2	3
6625-00-195-1579	1	15	6625-00-802-7485	6	2
5920-00-199-9498	2	8	6210-00-809-4274	4	93
5920-00-199-9498	4	94	5961-00-811-5799	3	2
5935-00-223-0572	10	9	5310-00-812-4294	14	12
5940-00-231-4430	3	17	5310-00-812-4294	15	12
5935-00-236-1087	4	73	5940-00-813-0698	4	19
5935-00-244-9919	8	1	5910-00-837-5109	4	34
5935-00-259-0071	10	8	5935-00-841-3386	7	15
5935-00-259-0205	1	12	5961-00-842-9864	5	9
5325-00-263-6648	4	23	5935-00-843-0144	4	70
5905-00-279-1751	5	1	5935-00-843-0144	9	10
5905-00-279-1757	5	8	5961-00-852-7549	5	18
5905-00-279-1867	5	4	5935-00-853-7596	4	56
5905-00-279-3513	5	10	5999-00-878-4714	14	7
5905-00-279-3516	5	11	5999-00-878-4714	15	7
5935-00-280-2195	8	2	5310-00-880-5978	4	29
5920-00-280-4960	2	9		4	90
5920-00-280-4960	4	95	5961-00-893-5938	4	42
5920-00-280-5002	2	7	5905-00-901-6988	4	47
5920-00-280-5002	4	91	5935-00-909-8565	4	9
5940-00-283-5280	4	31	5999-00-910-5054	14	1
5340-00-337-8642	4	53	5935-00-910-9177	11	4
5999-00-400-1534	7	14	4730-00-912-2293	4	81
5999-00-400-1534	11	5	5340-00-916-4350	4	85
5975-00-473-5595	4	49	5999-00-918-4046	4	8
5935-00-498-3620	4	71	6625-00-928-5410	4	80
5940-00-502-4522	4	26	6625-00-928-5412	4	83
5935-00-518-6983	11	16	5310-00-929-6395	3	12
5950-00-538-5662	4	77	5310-00-929-6395	4	3
5935-00-553-2949	11	20	5310-00-929-6395	11	18



STOCK NUMBER	FIGURE NO	ITEM NO	STOCK NUMBER	FIGURE NO	ITEM NO		
5935-00-929-7108	13	5	5940-00-935-3508	7	1		
5935-00-931-6831	7	16	5935-00-937-2782	13	1		
5310-00-933-8118	4	11	5961-00-949-1432	5	7		
5310-00-933-8118	7	6	5935-00-949-5647	14	2		
5310-00-933-8118	9	5	5961-00-957-6865	5	12		
5310-00-933-8118	11	9	5340-00-975-1440	4	25		
5310-00-933-8119	4	28	5935-00-983-7040	14	8		
5310-00-933-8120	3	6	5935-00-983-7040	15	8		
5310-00-933-8120	4	38	5120-00-996-4508	1	2		
5940-00-935-3508	4	7					
PART NUMBER	FSCM	FIG NO	ITEM NO	PART NUMBER	FSCM	FIG NO	ITEM NO
AN3420-10A	88044	11	21	MS16210-2	96906	7	7
AN3420-12A	88044	9	7	MS16210-2	96906	11	10
AN3420-12A	88044	10	10	MS16210-3	96906	3	13
AN3420-16A	88044	4	16	MS16210-3	96906	4	14
AN3420-16A	88044	7	9	MS16210-3	96906	11	19
AN3420-16A	88044	11	2	MS16210-4	96906	4	30
AN3420-16A	88044	11	12	MS16535-64	96906	4	54
AN3420-16A	88044	12	4	MS24265R22B55P	96906	12	7
AN3420-18A	88044	4	15	MS24266R22B55S	96906	4	17
AN3420-18A	88044	11	3	MS2466R12B12S	96906	10	2
AN3420-18A	88044	12	8	MS25036-1	96906	4	19
AN3420-8A	88044	10	1	MS25036-3	96906	4	33
				MS25036-50	96906	4	18
CH74LC13RN	81349	4	93	MS25036-6	96906	4	31
CLS632-2	46384	4	36	MS25036-8	96906	4	20
CS13BC475K	81349	5	20	MS25068-23	96906	4	82
CS13BF336K	81349	5	16	MS25125D1	96906	4	96
CS13BG226K	81349	5	6	MS25126C3	96906	4	59
CZ24BKF103	81349	4	34	MS25252NE2D	96906	4	90
C3M	06229	4	50	MS25256-2-327	96906	4	98
CBMF17W2S	91146	14	8	MS28136-4	96906	4	52
CBMF17W2S	91146	15	8	MS3057-12A	96906	10	9
CBM17W2P	91146	14	2	MS3057-6A	96906	8	2
DBM17W2P	71468	15	2	MS3102A14S1P	96906	4	73
CB24659	71468	14	4	MS3102A20-27S	96906	4	71
DB24659	71468	15	4	MS3102A28-21S	96906	4	65
CM51155	91146	14	1	MS3106A14S-1S	96906	8	1
DM51155	91146	15	1	MS3106A20-27P	96906	10	8
DM51157	91146	14	9	MS3116F18-32S	96906	12	3
DM51157	91146	15	9	MS35058-21	96906	4	58
DM53740-5001	91146	14	7	MS35058-23	96906	4	55
DM53740-5001	91146	15	7	MS35059-21	96906	4	60
DM53742-5001	91146	14	3	MS35338-134	96906	14	11
DM53742-5001	91146	15	3	MS35338-134	96906	15	11
DPD33-11612	71468	11	16	MS35338-135	96906	4	11
DPD45-33S1L	71468	11	20	MS35338-135	96906	7	6
DPJ59C10-34SB	71468	7	15	MS35338-135	96906	11	9
FHN20G	81349	4	92	MS35338-136	96906	3	12
F02A250V1/2A	81349	2	8	MS35338-136	96906	4	3
F02A250V1/2D	81349	4	94	MS35338-136	96906	11	18
F02A250V2A	81349	2	9	MS35338-137	96906	4	28
F02A250V2A	81349	4	95	MS35338-138	96906	3	6
F03A250V10A	81349	2	7	MS35338-138	96906	4	38
F03A250V10A	81349	4	91	MS35338-185	96906	9	5
HP3N	09922	3	20	MS35431-8	96906	3	5
HP3N	09922	4	44	MS35431-8	96906	4	43
HP4N	09922	3	19	MS35489-135	96906	4	23
HP6N	09922	4	25	MS51957-15	96906	4	68
HP8N	09922	4	21	MS51957-16	96906	4	1
HP9N	09922	4	53	MS51957-16	96906	7	5
JAN1N1202	81349	3	2	MS51957-16	96906	11	8
JAN1N2982B	81349	4	42	MS51957-26	96906	4	51
JAN1N3611	81349	5	12	MS51957-27	96906	4	22
JAN1N486B	81349	5	5	MS51957-29	96906	3	18
JAN1N754A	81349	5	18	MS51957-29	96906	4	2
JAN1N914	81349	5	9	MS51957-3	96906	14	10
JAN2N2219A	81349	5	7	MS51957-3	96906	15	10
LH74LC13WT	81349	4	89	MS51957-30	96906	4	5
MS15795-803	96906	4	69	MS51957-31	96906	9	4
MS15795-805	96906	3	11	MS51957-44	96906	4	84
MS15795-805	96906	4	4	MS51957-47	96906	4	27
MS15795-807	96906	4	29	MS51958-64	96906	3	8
MS15795-808	96906	3	9	MS51959-16	96906	4	75
MS15795-808	96906	4	39	MS51959-31	96906	11	17
MS16210-2	96906	4	12	MS51960-65	96906	4	79

PART NUMBER	FSCM	FIG NO	ITEM NO	PART NUMBER	FSCM	FIG NO	ITEM NO
MS91528-2K4B	96906	4	97	360088	80249	3	16
NAS671C10	81349	3	7	410125	80249	4	66
NAS671C10	81349	4	37	41842	00779	3	17
NAS671C2	80205	14	12	41842	00779	4	32
NAS671C2	80205	15	12	51-008-0000	98291	13	5
N5	06229	4	49	51-011-0000	98291	13	1
PAM33MG6-6-250VAC400CPS	74193	4	88	51609-1	00779	4	64
RC20GF114J	81349	5	4	564F4	70276	2	4
RC20GF152J	81349	5	8	610071	80249	4	83
RC20GF221J	81349	5	10	610072	80249	4	80
RC20GF302J	81349	5	1	61023-42	80249	7	11
RC20GF471J	81349	5	19	6108SS0832-7	06540	4	86
RC20GF910J	81349	5	11	6312CSS0832	06540	4	87
				651014-1	80249	2	6
RN70C17220	81349	5	15	651014-2	80249	4	72
RW67G101	81349	5	14	651014-3	80249	2	1
RW68V270	81349	4	47	651018	80249	2	2
SE099E02	81349	4	46	651023-11	80249	9	2
ST752895-112	80249	5	2	651023-17	80249	12	6
S283-2-1	07418	9	6	651023-18	80249	12	9
S428-1	07418	7	16	651023-23	80249	7	12
UG1094BU	81349	4	56	651023-24	80249	9	8
UG201U	81349	1	12	651023-25	80249	9	1
UG636AU	81349	1	11	651023-26	80249	9	11
ZSP6-602	98376	6	3	651023-26	80249	11	15
1-202301-0	00779	7	8	651023-26	80249	14	5
1-202301-0	00779	11	11	651023-26	80249	15	5
1-331950-0	00779	4	6	651023-27	80249	10	6
1-332056-0	00779	4	7	651023-28	80249	10	4
1-332056-0	00779	7	1	651023-29	80249	10	5
117547-6	80249	4	63	651023-30	80249	10	7
119057-1	80249	4	74	651023-31	80249	10	3
119058-1	80249	1	14	651023-32	80249	11	22
119064-1	80249	4	45	651023-33	80249	11	14
119066-1	80249	2	5	651023-34	80249	12	2
119067-1	80249	3	1	651023-35	80249	12	5
119073-1	80249	1	13	651023-36	80249	12	1
119076-1	80249	1	15	651023-4	80249	7	10
119077-1	80249	1	16	651023-43	80249	13	3
119078-1	80249	1	17	651023-44	80249	13	2
119079-1	80249	1	18	651023-45	80249	13	4
119095-1	80249	4	35	651023-46	80249	14	6
119106-1	80249	4	24	651023-47	80249	15	6
119155-1	80249	1	4	651023-5	80249	7	13
119162-1	80249	1	19	651023-6	80249	8	5
119163-1	80249	1	20	651023-6	80249	11	1
119163-2	80249	1	21	651023-7	80249	8	4
119165-1	80249	1	7	651023-8	80249	8	3
119165-2	80249	1	5	651023-8	80249	9	9
119165-3	80249	1	10	651023-8	80249	11	13
119165-4	80249	1	9	651023-8	80249	14	13
119198-1	80249	1	8	651023-8	80249	15	13
119198-2	80249	1	6	66098-1	00779	11	4
119598-1	80249	1	1	66100-1	00779	4	8
1212-2	71279	4	81	66102-1	00779	7	14
1292-2	71279	4	85	66102-1	00779	11	5
147-4-032BRASSHT	79963	4	10	66104-1	00779	4	9
147-6-032BRASSHT	79963	4	13	690273	80249	3	10
191P22492T16	56289	3	14	8TB8	81349	4	26
202287-1	00779	7	3	841104	80249	4	99
202287-1	00779	11	6	850186-1	80249	4	57
202650-2	00779	11	7	880007	80249	1	2
202650-2	07799	7	4	880177	80249	1	3
202651-2	00779	4	62	890358-1	80249	4	78
202795-1	00779	4	61	890359-1	80249	4	77
2034-2-05	71279	5	3	890360	80249	3	15
2829-75-1	98159	5	5	930120-2	80249	3	4
331952-0	00779	7	2	930120-2	80249	4	41
332F4	70276	2	10	930129-8	80249	3	3
340297-3	80249	4	67	930129-8	80249	4	40
341082	80249	4	76	94-52548-1	02660	4	70
360087	80249	2	3	94-52548-1	02660	9	10
360087-1	80249	6	2	94-62548-1	02660	9	3
360087-2	80249	6	1				

## LATEST NATIONAL STOCK NUMBER ASSIGNMENTS

STOCK NUMBER	FIGURE NO.	ITEM NO.
5895-00-089-4403	2	11
5905-00-141-1311	5	17
5935-00-153-8455	15	2
5895-00-782-0844	2	11
5910-00-869-4855	4	48
5330-00-873-3450	5	5
5355-00-899-9014	4	97
5340-00-946-9440	4	50

## LATEST PART NUMBER ASSIGNMENTS

PART NUMBER	FSCM	FIG. NO.	ITEM NO.
CE71C681J	81349	4	48
C-6280(P)/APX	80058	2	11
C-6280A(P)/APX	80058	2	11
RC32G202JR	81349	5	17

By Order of the Secretary of the Army:

BERNARD W. ROGERS  
*General, United States Army*  
*Chief of Staff*

Official:

PAUL T. SMITH  
*Major General, United States Army*  
*The Adjutant General*

DISTRIBUTION:

To be distributed in accordance with DA Form 12-36A, Organizational avionics test equipment literature requirements for AN/APM-239A. ,,

\* U.S. GOVERNMENT PRINTING OFFICE : 1983 0 - 381-302 (1333)



# SOMETHING WRONG WITH THIS MANUAL?

THEN... JOT DOWN THE DOPE ABOUT IT ON THIS FORM. TEAR IT OUT, FOLD IT AND DROP IT IN THE MAIL!

FROM: (YOUR UNIT'S COMPLETE ADDRESS)

DATE

PUBLICATION NUMBER

DATE

TITLE

BE EXACT... PIN-POINT WHERE IT IS

IN THIS SPACE TELL WHAT IS WRONG AND WHAT SHOULD BE DONE ABOUT IT:

PAGE NO.	PARA-GRAPH	FIGURE NO.	TABLE NO.
----------	------------	------------	-----------

TEAR ALONG DOTTED LINE

TYPED NAME, GRADE OR TITLE, AND TELEPHONE NUMBER

SIGN HERE:

DA FORM 2028-2 (TEST)  
1 AUG 74

P.S.--IF YOUR OUTFIT WANTS TO KNOW ABOUT YOUR MANUAL "FIND," MAKE A CARBON COPY OF THIS AND GIVE IT TO YOUR HEADQUARTERS.

FILL IN YOUR  
UNIT'S ADDRESS

FOLD BACK

DEPARTMENT OF THE ARMY

OFFICIAL BUSINESS

PENALTY FOR PRIVATE USE, \$300

Commander  
US Army Electronics Command  
ATTN: DRSEL-MA-Q  
Fort Monmouth, New Jersey 07703

FOLD BACK

TEAR ALONG DOTTED LINE

